



	1x
	1x
	1x
	1x
	2x
	2x

Montageanleitung

Eckschrank-Schwenkauszug
 LeMans II
 (mit höhenverstellbarer Achse)
 45er, 50er, und 60er Schränke

Mounting Instruction

Full Swing Corner Pull-out
 LeMans II
 (with height adjustable axle)
 For 450, 500 and 600 mm cabinets

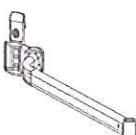
Instruction de montage

Système pivotant LeMans II
 pour meuble d'angle
 (Avec axe réglable en hauteur pour
 meuble de 450, 500 et 600 mm largeur)

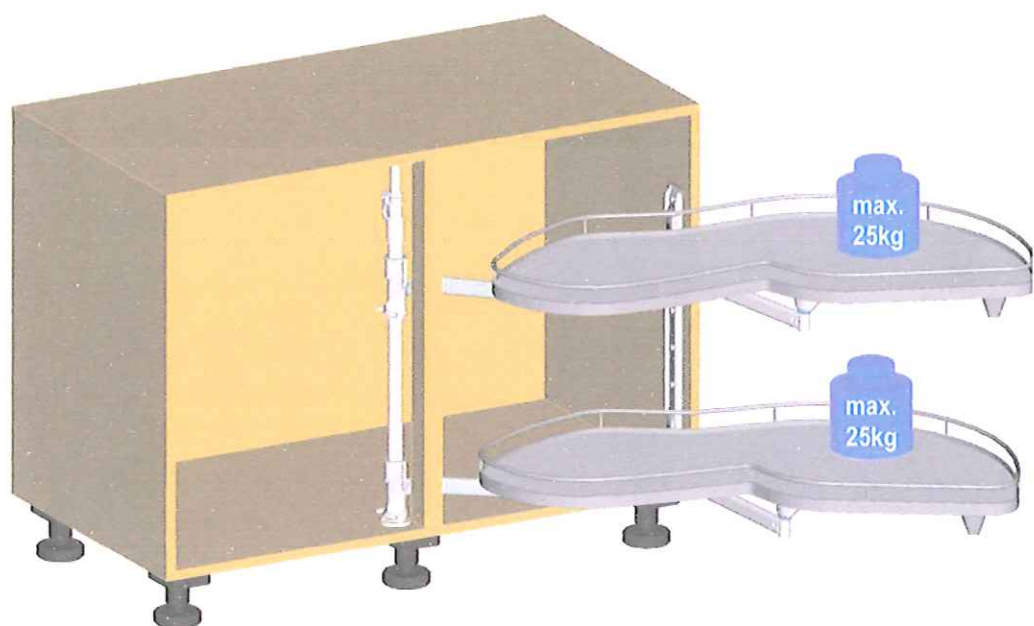

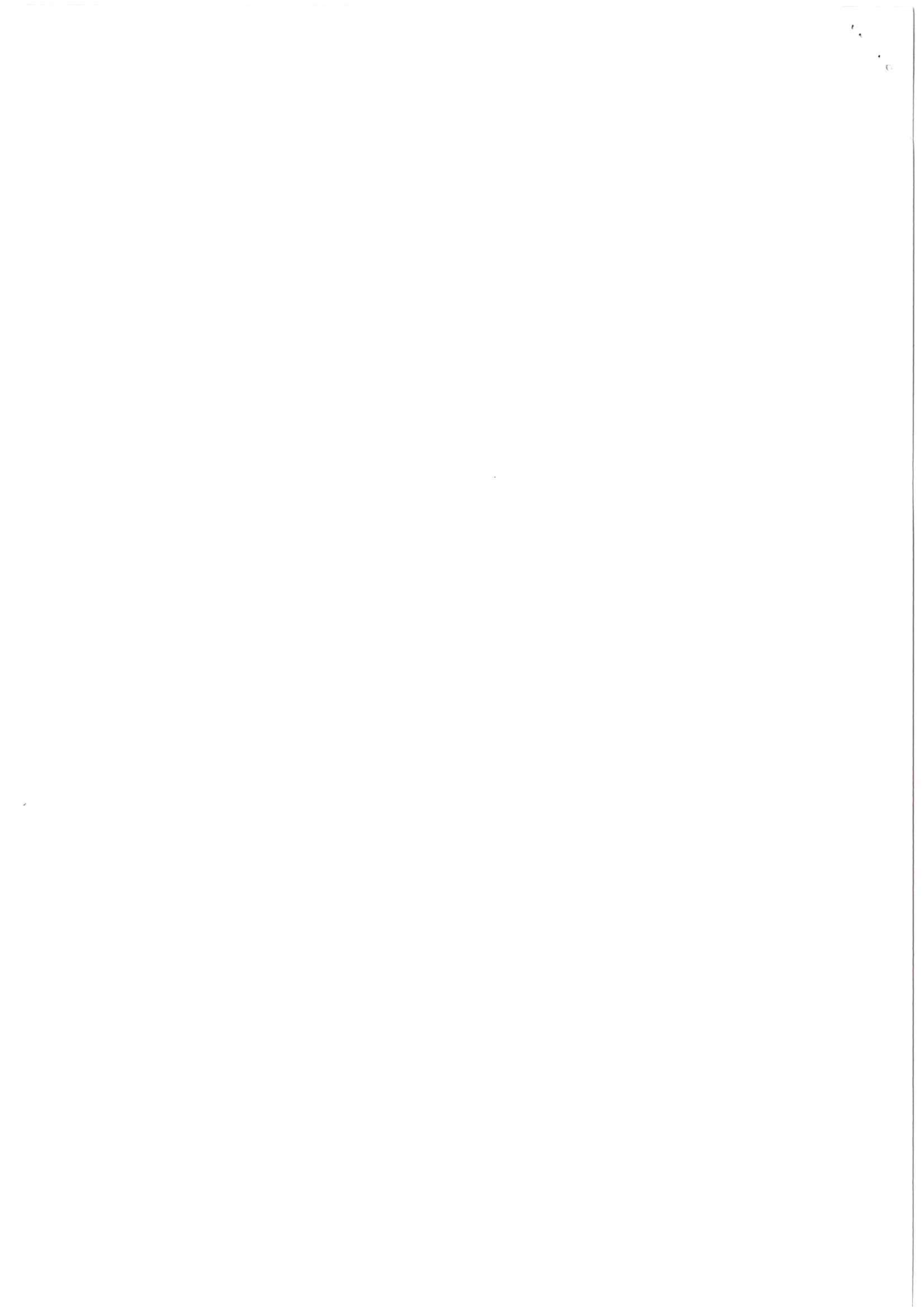

SYMBOLE • SYMBOLS • SYMBOLES • SYMBOLI • SIMBOLOS • SIMBOLOS • MERKIT • SYMBOLER • SYMBOLY • SYMBOLE •



Warnung! • Warning! • Avertissement! • Avvertenza! • ¡Advertencia! • Aviso! • Varoitus! • Advarsel! • Výstraha! • Ostrzezenie!



Nicht korrekt! • Incorrect! • Incorrect! • Non corretto! • ¡Incorrecto! • Incorrecto! • Väärin! • Ikke korrekt! • Nesprávne! • Nieprawidłowo!



Korrekt! • Correct! • Correct! • corretto! • ¡Correcto! • Correcto! • Oikein! • Korrekt! • Správne! • Prawidłowo!



Fixieren/fixiert! • Secure/Secured! • Fixer/fixé • Fissare/fissato! • ¡Fijar/fijado! • Fixar/fixo! • Kiinnitä/kiinnitetty! • Spænde/sændt •



Lösen/gelöst! • Release/Released! • Détacher/détaché • Allentare/allentato! • ¡Soltar/suelto! • Soltar/solto! • Irroita/irroitettu! • Løsne/løsnet • Povolit/povolento! • Zwolnic/zwolnione!



Keinen Akkuschauber verwenden! • Do not use a cordless screwdriver! • Ne pas utiliser de tournevis à piles • Non utilizzare un avvitatore a batteria! • ¡No utilizar tladro atomillador! • Não usar aparafusadora sem fio! • Älä käyttää akkuruvinväännintä! • Brug ikke batteriskruetrækker! • Nepouzujte akušroubovák! • Nie używac wkrtaarki akumultorowej!



PZ2-Schraubendreher verwenden! • Use a PZ2 screwdriver! • Utiliser un tournevis Pz2 • Usare il cacciavite Pz2! • ¡Utilizar un destornillador Pz2! • Usar chave de parafusos Pz2! • Käytä PZ2-ruuviataltaa! • Brug PZ2-skrueetrækker! • Pouzijte krizový šroubovák Pz2! • Użyc wkrętaka Pz2!



Optionales Element! • Optional element! • Élément optionnell! • Elemento opzionale! • ¡Elemento opcional! • Elemento opcional! • Valinnainen elementti! • Valgfrit element! • Vollitelný prvek! • Element opcjonalny!



Klick-Geräusch beim Einrasten! • Audible click on engagement! • <<Clic>> lors de l'encliquetage • Quando si innesta si sente un clic! • ¡Ciaondo encaja se oye un clic! • Ruído de clique ao engatar! • Lukittuessa kuuluu klik-ääni! • Klikyd ved monterging! • Slysitelné zacvaknutí! • Trzask przy zaskakiwaniu!



Alle Maße in mm! • All dimensions in mm! • Toutes les dimensions en mm! • Tutte le dimensioni in mm! • ¡Todas las medidas son en mm! • Todas as medidas em mm! • Kaikki mitat mm! • Alle mal er mm! • Vsechny rozmery v mm! • Wszystkie wymiary w mm!

Die technische Darstellung und Maßangaben -auch bei Abbildungen und Zeichnungen - sind unverbindlich. Konstruktionsverbesserungen sind vorbehalten! • Technical information and stated dimensions (including in illustrations and drawings) must not be regarded as binding. Design subject to change without notice (in interest of improvement)! • Les illustrations technique et les cotes y compris sur les schémas et les dessins sont non contractuelles. Sous réserve d'améliorations de la construction! • Le rappresentazioni tecniche e le indicazioni delle dimensioni anche nelle figure e nei disegni non sono vincolanti. Con riserva di miglioramenti di progettazione! • Las descripciones técnicas y los datos dimensionales, inclusive los incluidos en fotos y figuras, son meramente orientativos y no vinculantes. ¡Reservado el derecho a mejoras constructivas! • As descrições técnicas e as indicações de medidas também em ilustrações e desenhos não são de natureza imperativa. Salvo melhoramentos de construção! • Tekniset piirrokset ja mitat myös kuvissa ja piirroksissa olevat ovat sitoumuksetta. Oikeus teknisiin parannuksiin pidätetään! • De tekniske fremstillinger og måleangivelser også i figurer og tegninger er vejledende. Forbehold for konstruktionsforbedringer! • Technické znázornění a rozměry i na obrázcích a výkresech jsou nezávazné. Konstrukční změny vyhrazeny! • Prezentacje techniczne i dane wymiarowe także na rysunkach są niewiązane. Zmiany konstrukcyjne zastrzeżone!

1

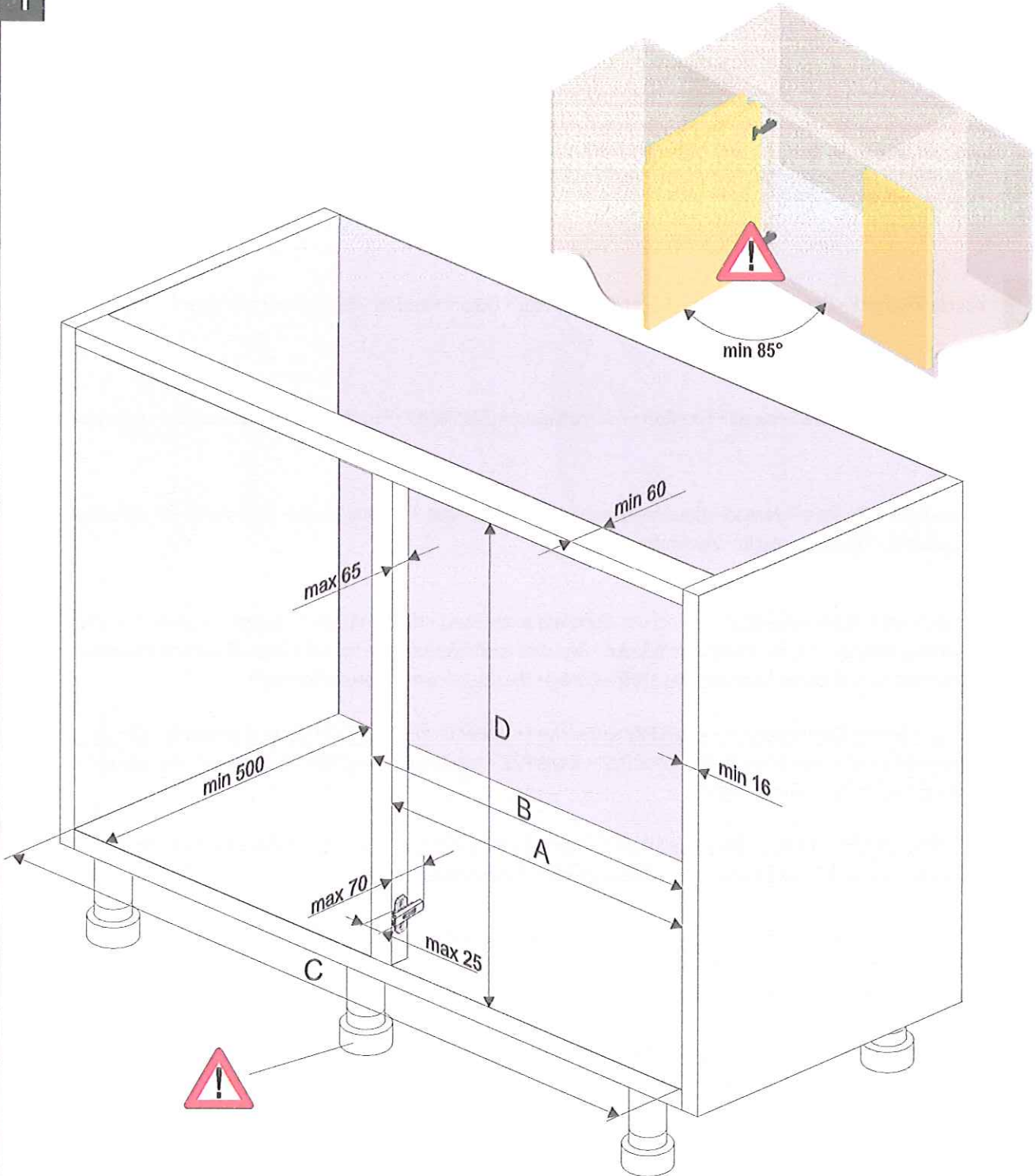

		Maß mm measur. Cote	A	B	C
	LeMans 45		411 - 418	max. 450	min. 800
	LeMans 50		461 - 468	max. 500	min. 910
	LeMans 60		561 - 568	max. 600	min. 960

	D
Achse axle axe	600 - 750
	720 - 900

Anschraubpositionen festlegen

Locate bolting positions

Déterminer l'emplacement des vis

Verwendung der Bohrschablonen (S. 4)

usage of mounting template (p. 4)

utilisation du gabarit de perçage (p. 4)

Ausmessen der Anschraubpositionen (S. 5)

measuring screw positions (p. 5)

mesurer des positions à visser (p. 5)

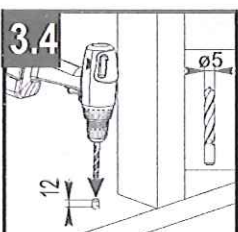
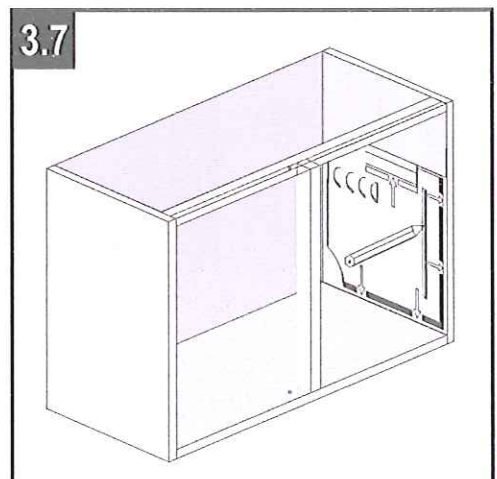
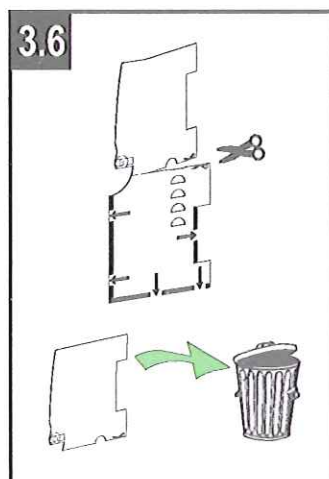
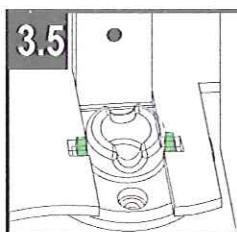
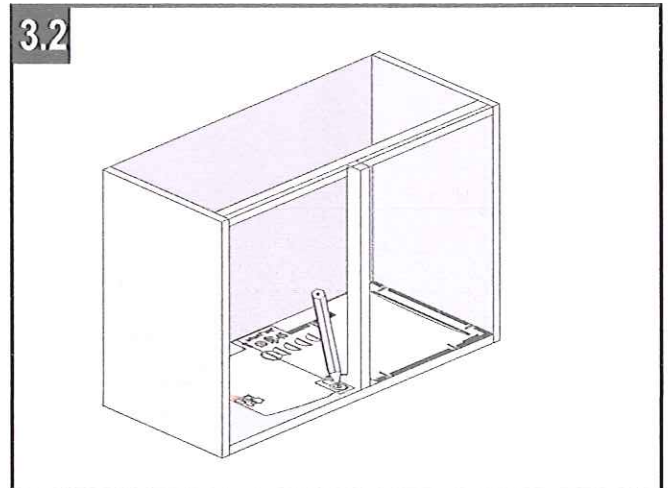
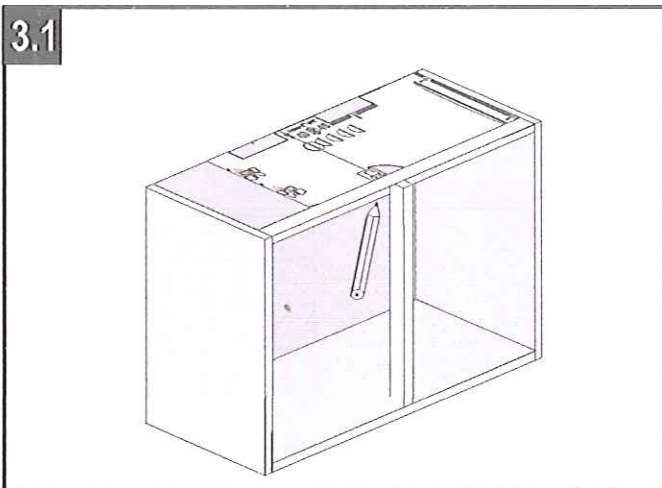
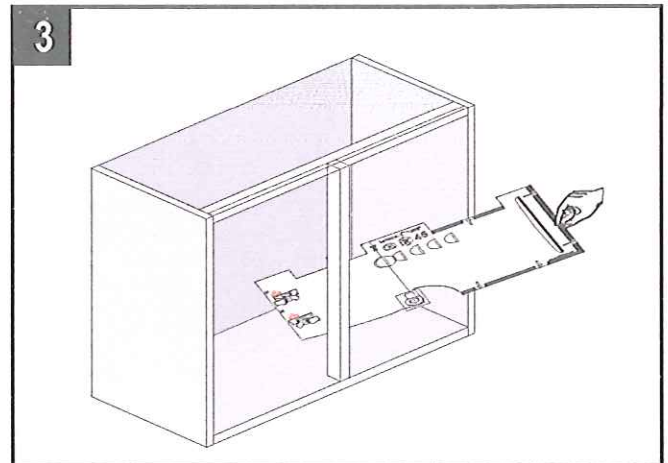
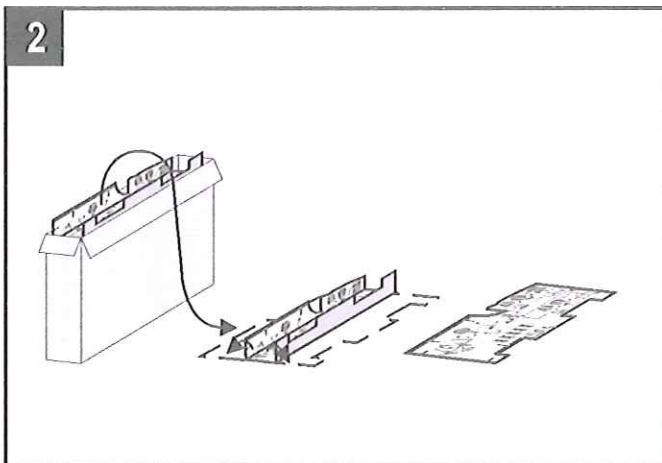

4

Tür door Porte	X
LeMans 45	476mm
LeMans 50	526mm
LeMans 60	626mm

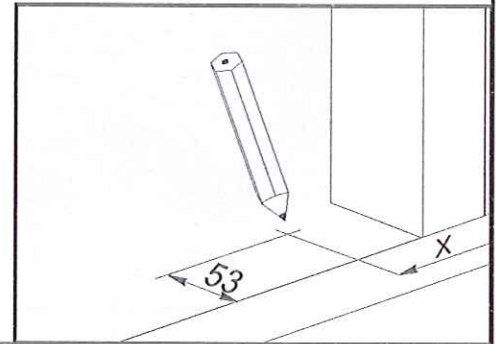
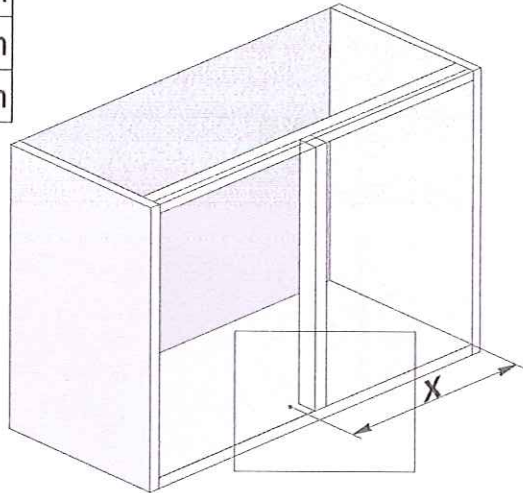

5

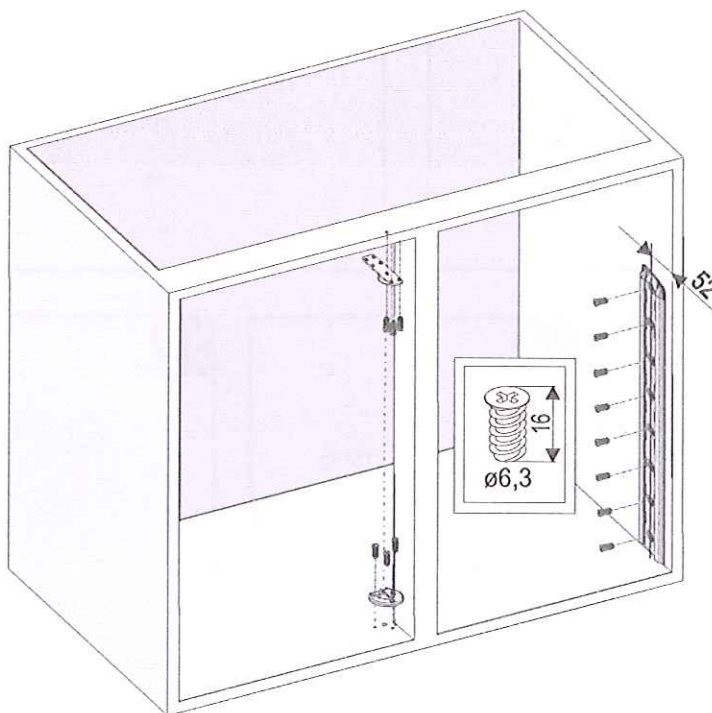
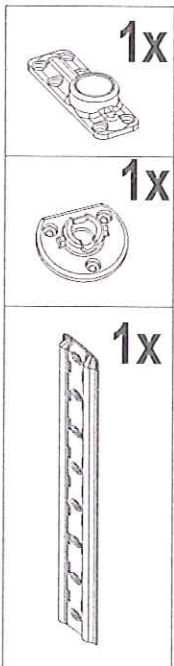

H	500	600
Y	28	64
X	64	64

Bohrtiefe Ø5 = 13mm

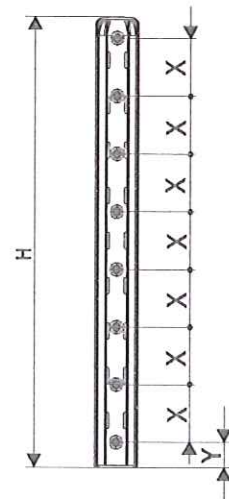

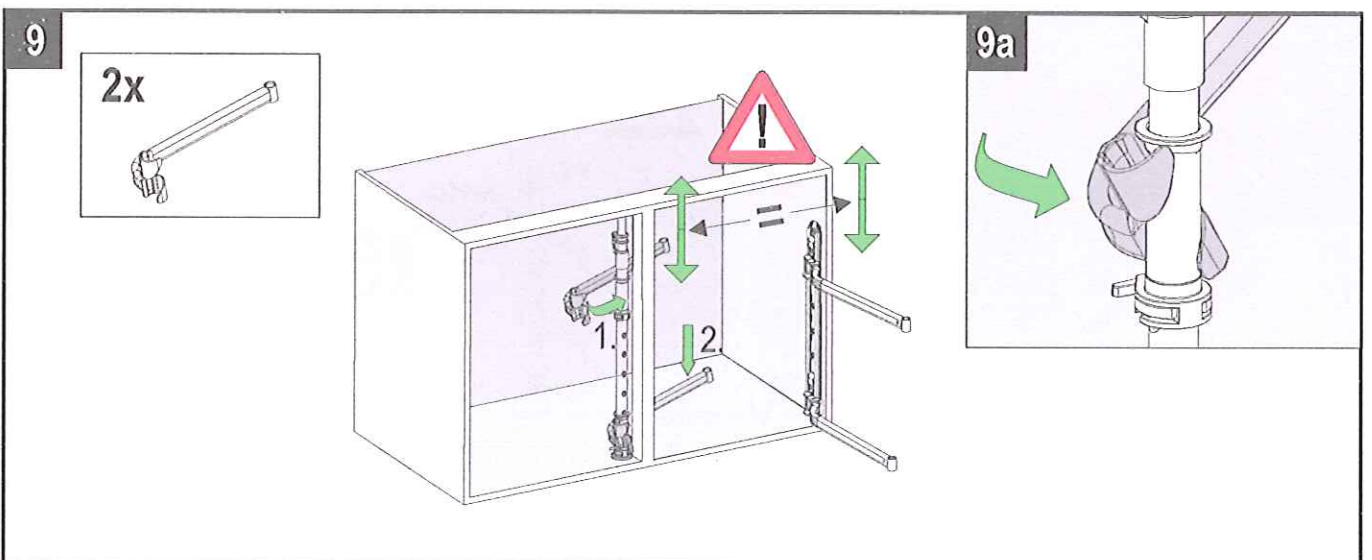
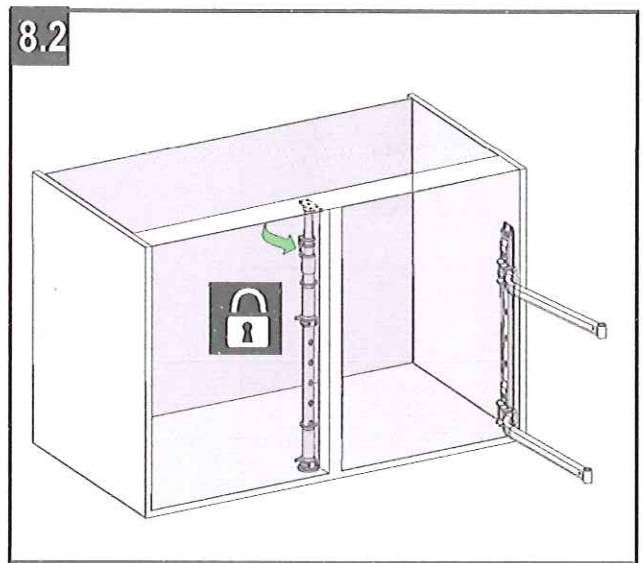
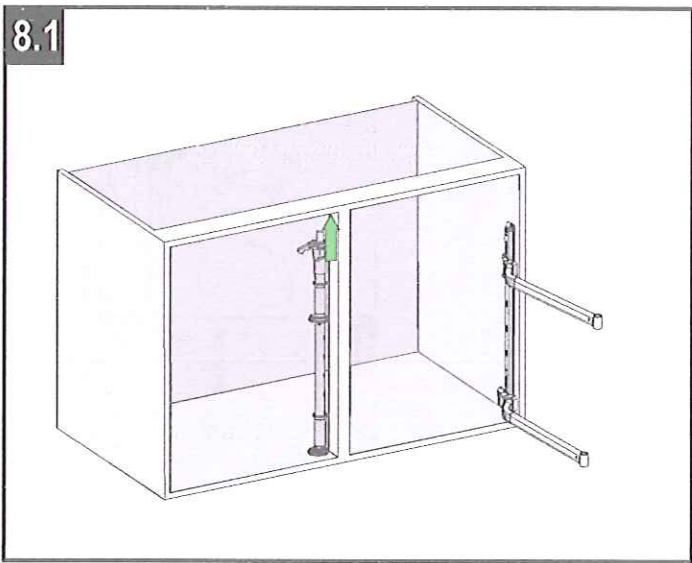
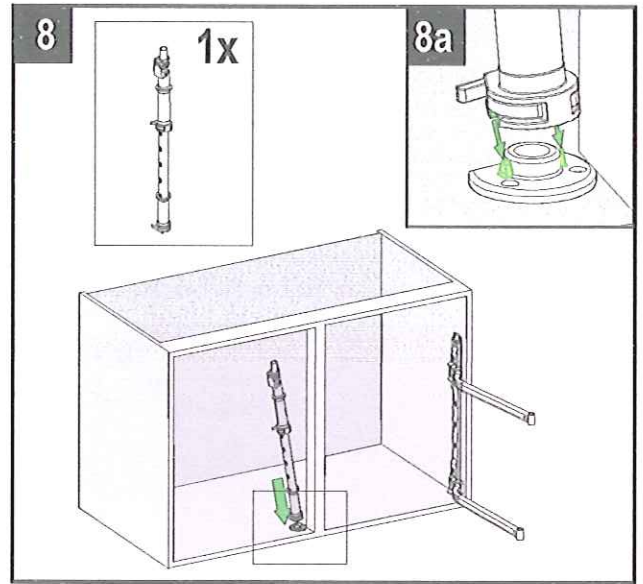
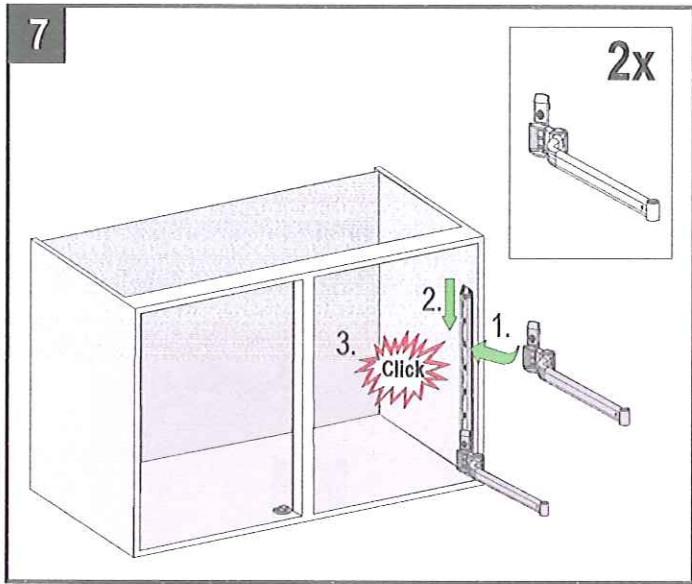

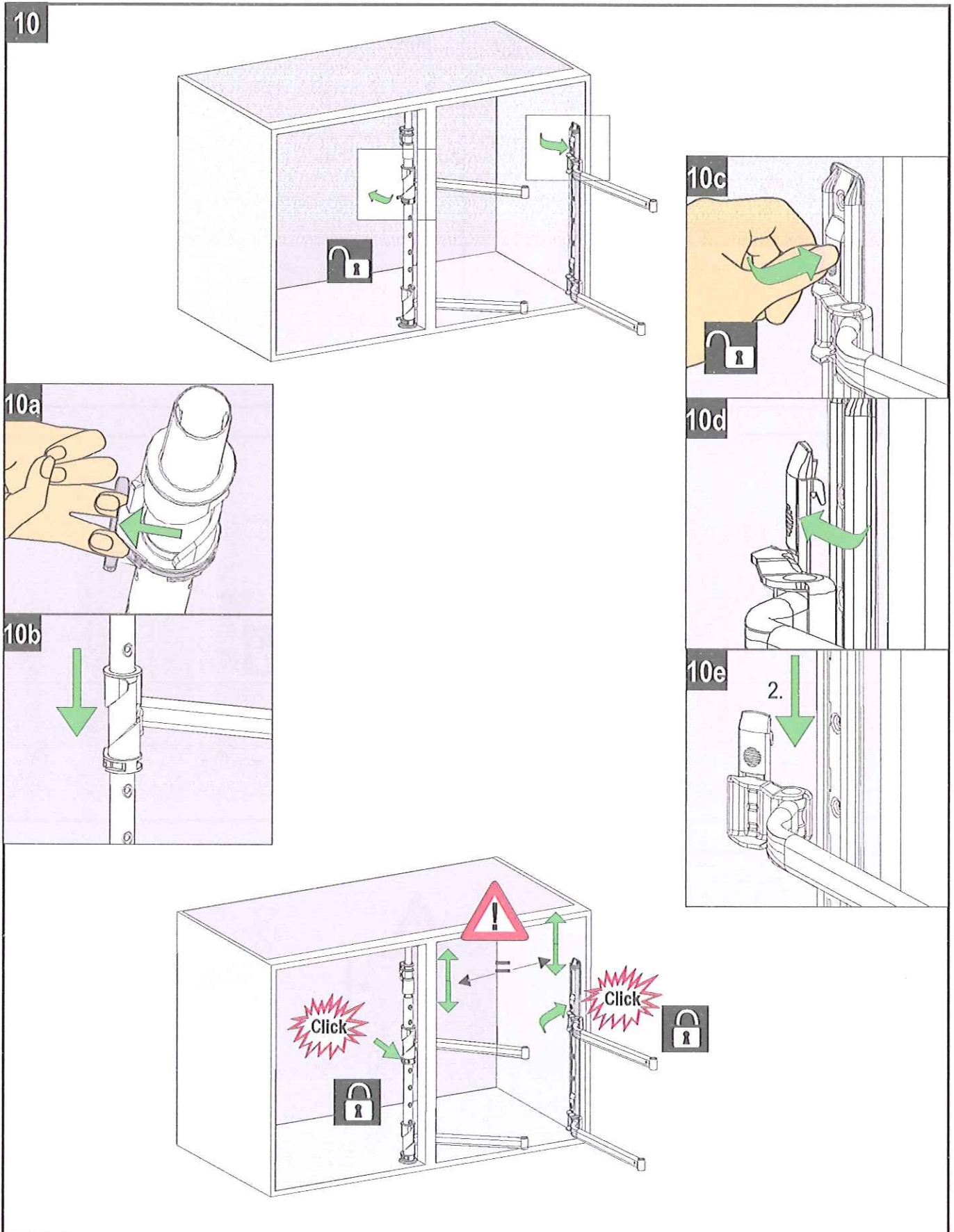

11

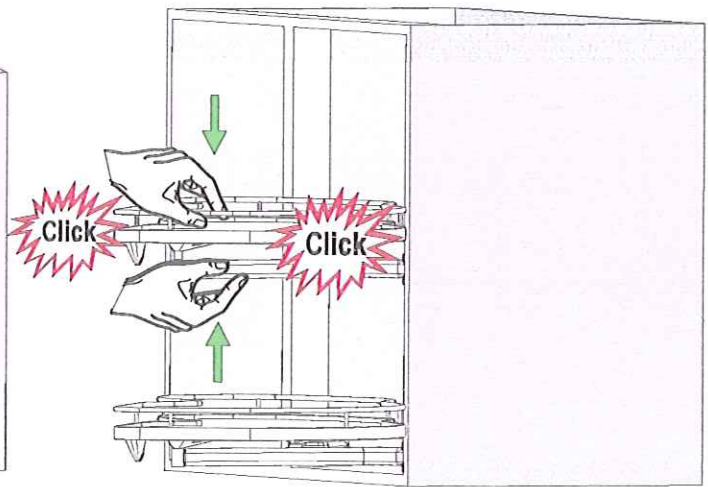
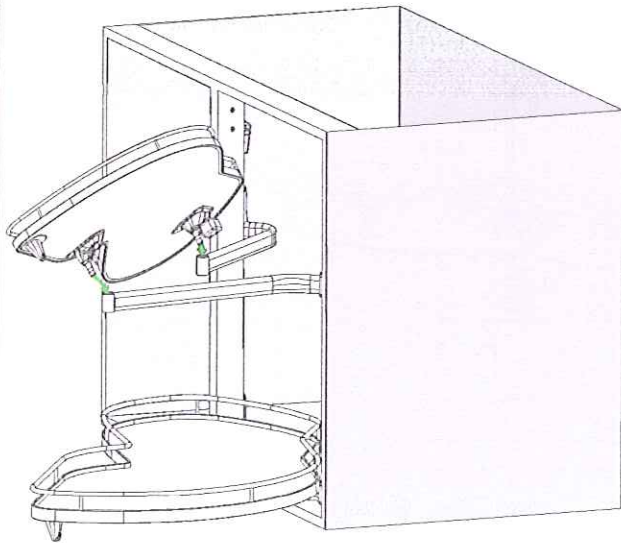
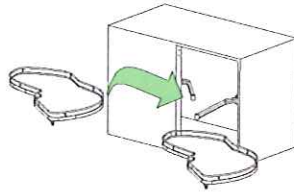
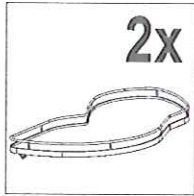

12

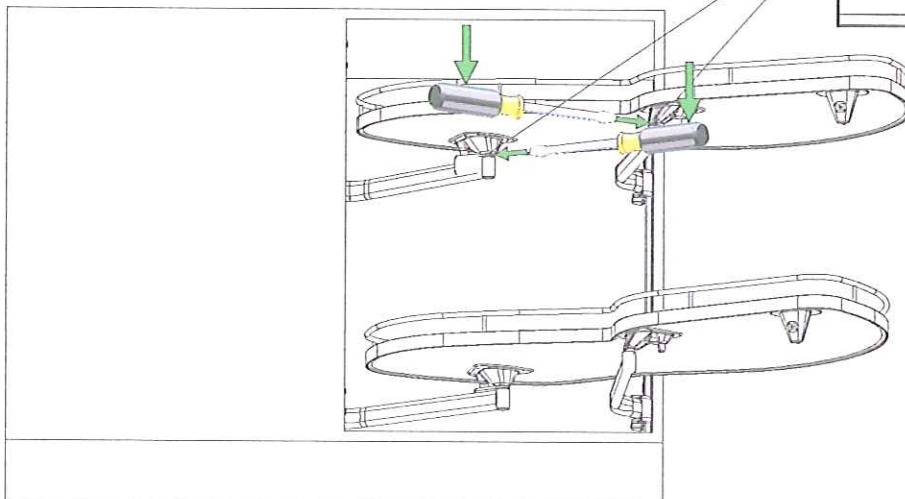
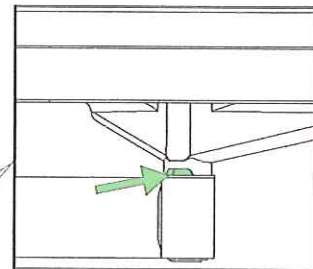
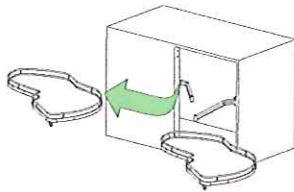

13

