

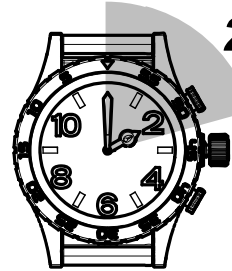

Demeyere
GROUP

169667 - 00

- (FR)** NOTICE DE MONTAGE
- (EN)** ASSEMBLY INSTRUCTIONS
- (DE)** MONTAGEANLEITUNG
- (ES)** INSTRUCCIONES DE MONTAJE
- (NL)** MONTAGEVOORSCHRIFT
- (IT)** ISTRUZIONI DI MONTAGGIO
- (PT)** INSTRUÇÕES DE MONTAGEM
- (PL)** INSTRUKCJA MONTAŻU
- (CR)** NAPUTCI ZA MONTAŽU

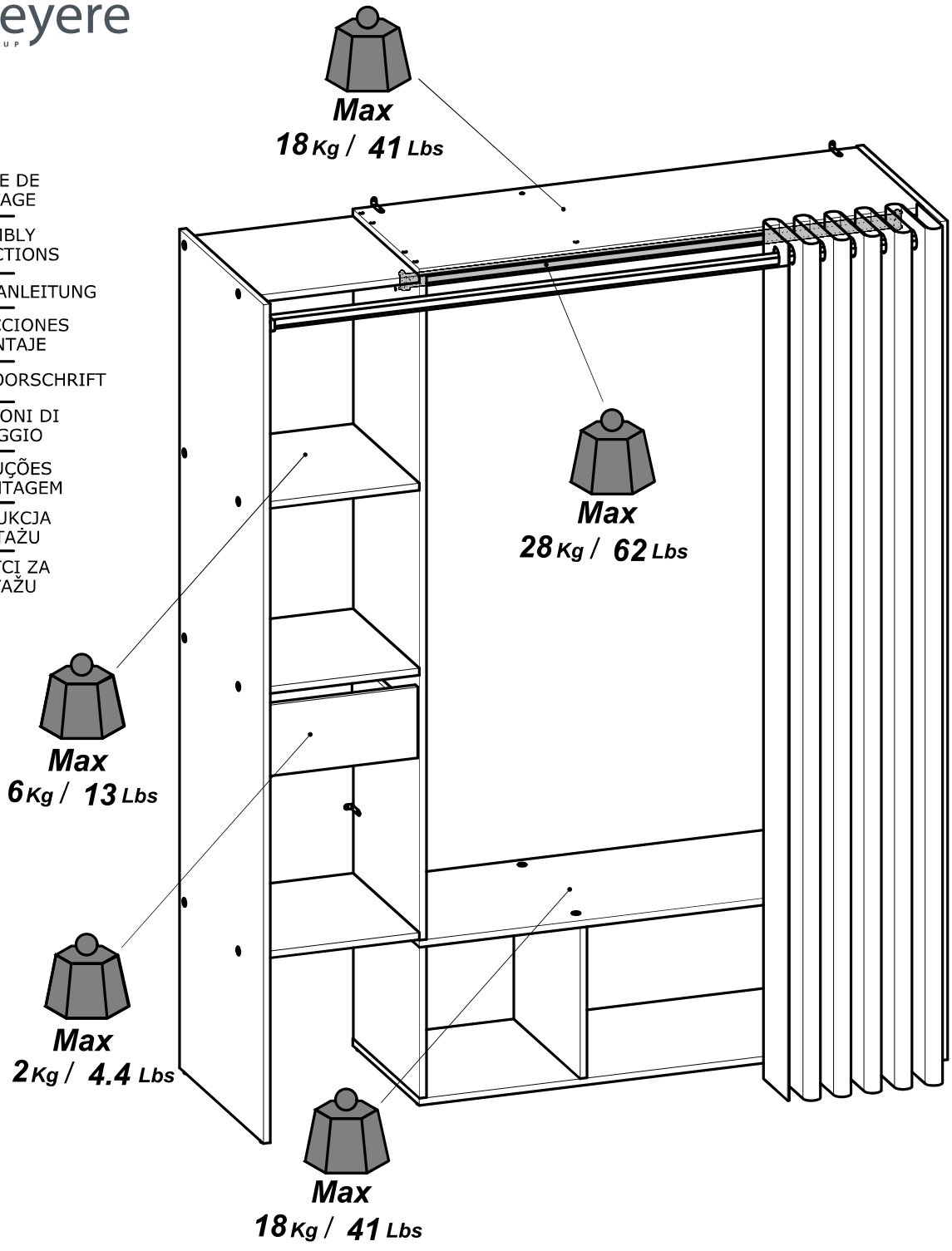

2h30.

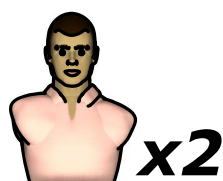

168243



Fabriqu  en France
Made in France

S.A. Meubles DEMEYERE - 178-184 rue de la Pr v t 
59840 P renchies - FRANCE

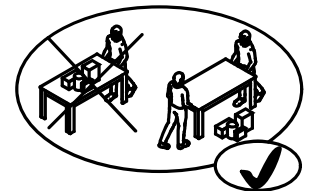
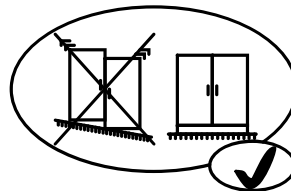
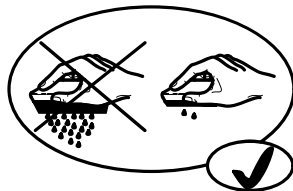
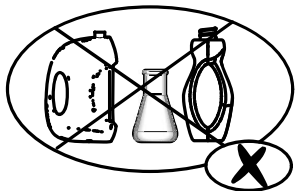
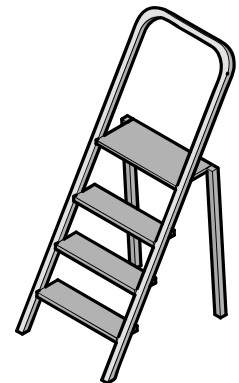
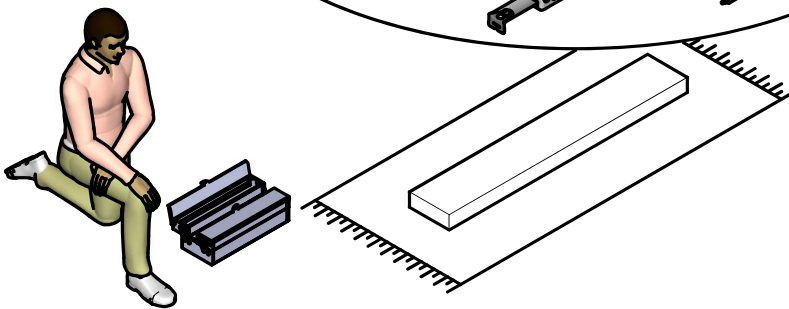
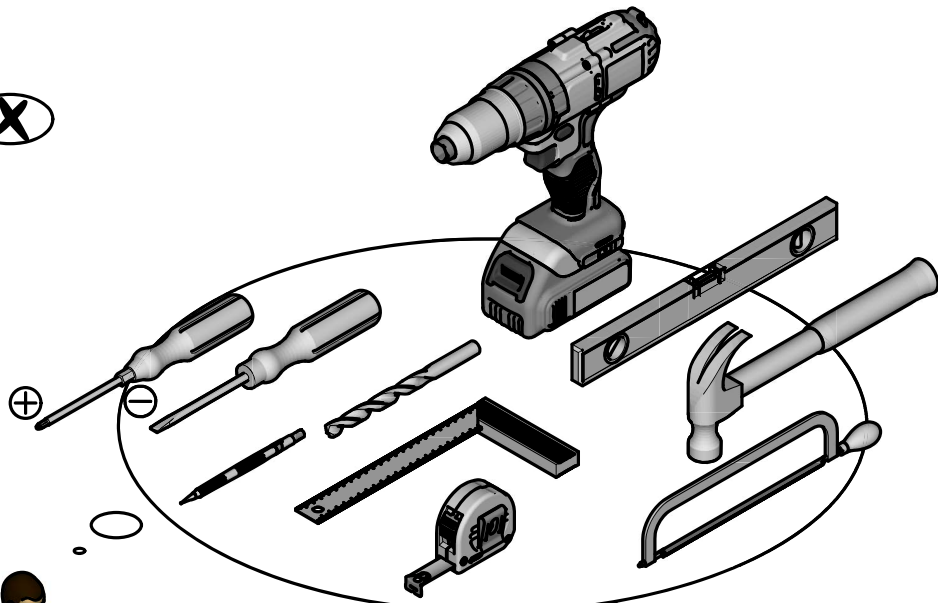
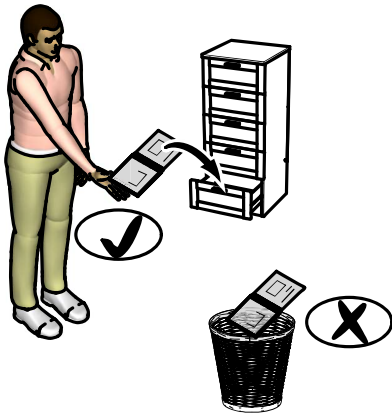
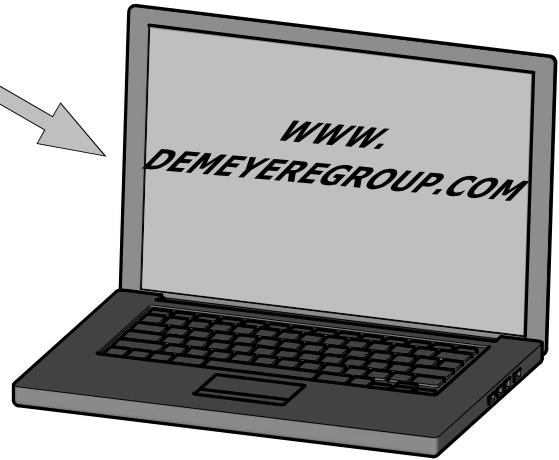
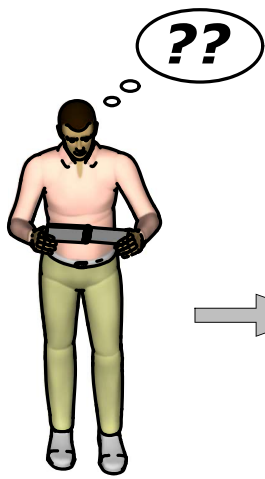

Donnez ou recyclez vos meubles.

Association ou

Magasin ou

Déchèterie

<https://www.demeysers.com>



A x1

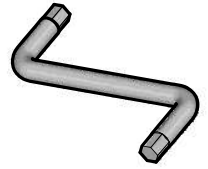

B x1

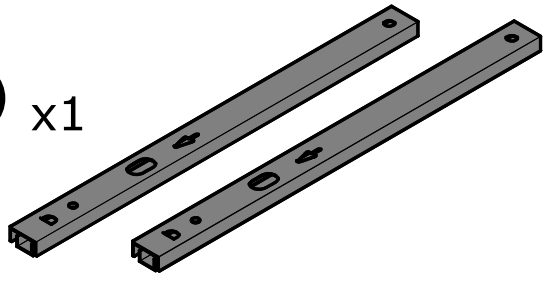

C x26

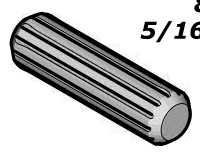

8x30mm
5/16" x 1 3/16"

D x4



6,3x9mm
1/4" x 11/32"

E x4



3x12mm
1/8" x 15/32"

F x3



3,5x15mm
1/8" x 19/32"

G x2



4x9mm
5/32" x 11/32"

H x24



I x1

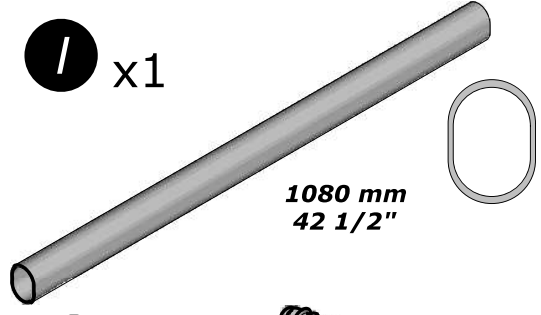

1080 mm
42 1/2"

J x2



K x1

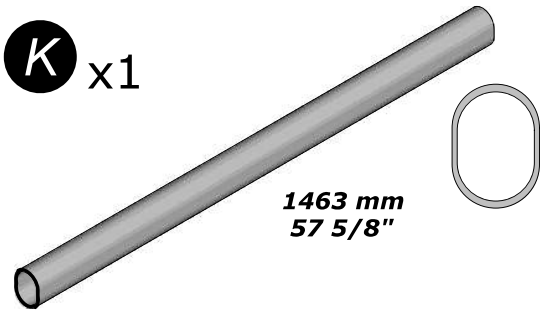

1463 mm
57 5/8"

L x4

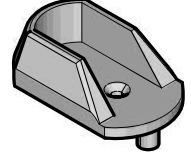

M x2

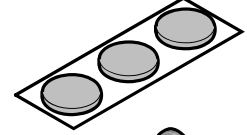

N x3

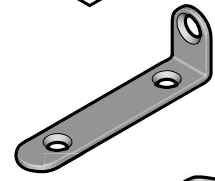

O x1

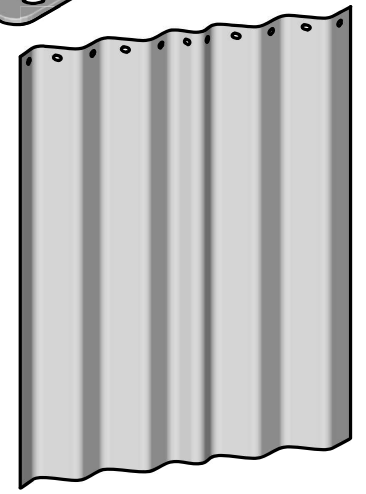

P x4

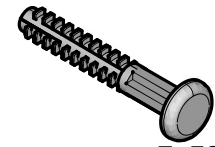

7x50mm
9/32" x 1 31/32"

Q x30

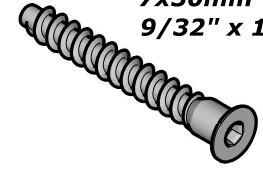

R x2



Ø12mm
Ø15/32"

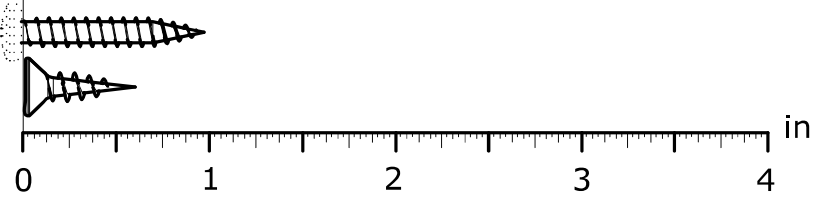
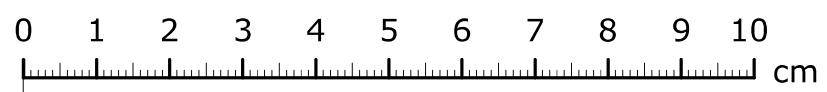

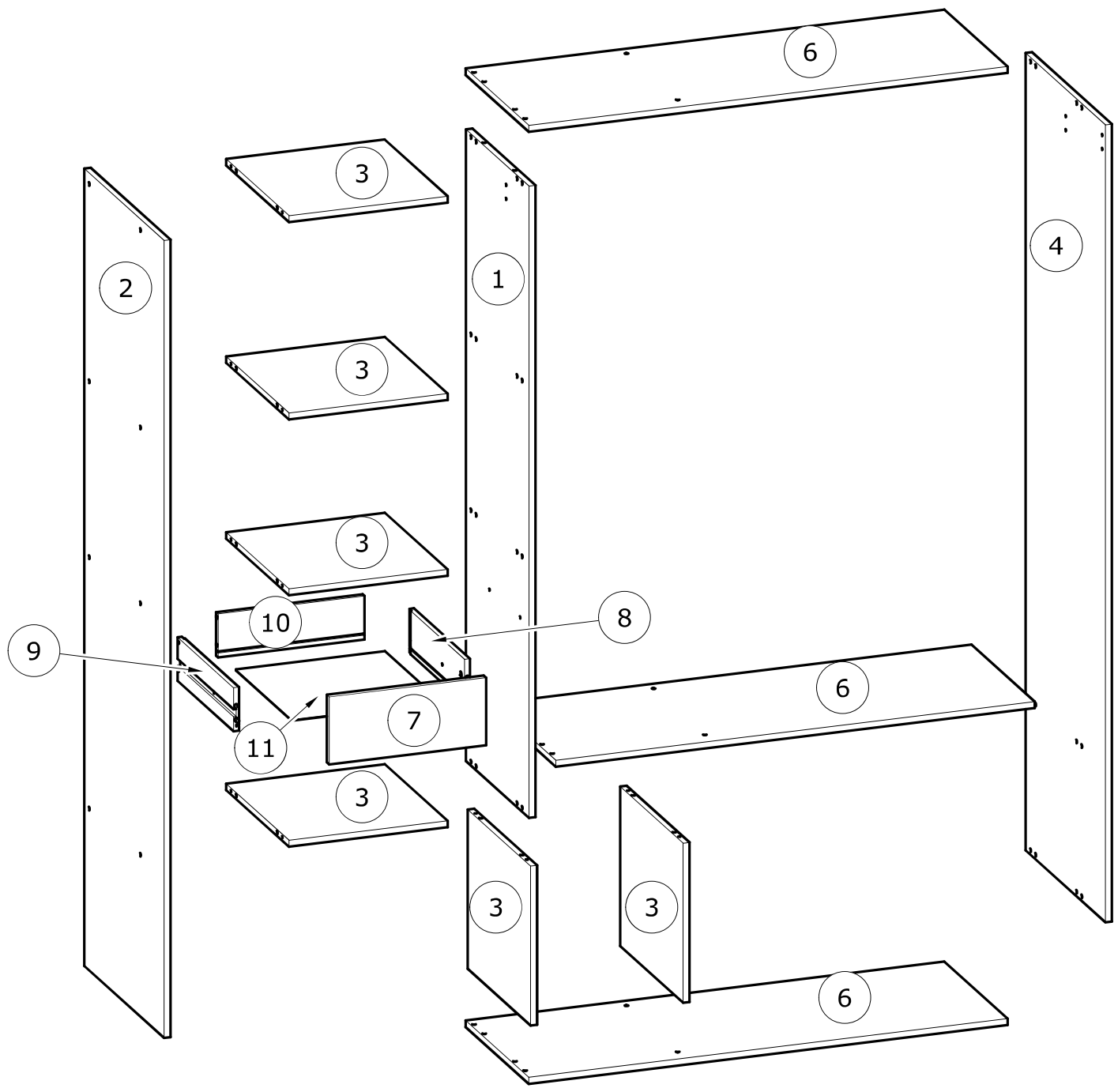

N°	MM		INCH		QTY
1	1 414	x 394	55 11/16	x 15 8/16	1
2	1 830	x 499	72 1/16	x 19 10/16	1
3	366	x 393	14 7/16	x 15 8/16	6
4	1 830	x 499	72 1/16	x 19 10/16	1
6	1 105	x 395	43 8/16	x 15 9/16	3

N°	MM		INCH		QTY
7	362	x 155	14 4/16	x 6 2/16	1
8	350	x 100	13 12/16	x 3 15/16	1
9	350	x 100	13 12/16	x 3 15/16	1
10	338	x 100	13 5/16	x 3 15/16	1
11	344	x 348	13 9/16	x 13 11/16	1

FR

AVERTISSEMENT : MEUBLE A FIXER IMPERATIVEMENT AU MUR AFIN D'EVITER SON BASCULEMENT

- Pour installer correctement ce produit et éliminer les risques pour votre sécurité, merci de suivre exactement ce manuel d'instruction.
- Fixer le meuble au mur avec les attaches prévues à cet effet
- Les vis et les chevilles ne sont pas fournies. Utiliser des vis et des chevilles adaptées au support.

EN

WARNING: FURNITURE TO BE ATTACHED TO THE WALL TO PREVENT OVERTURNING

- Installation shall be carried out exactly according to those instructions-otherwise a safety risk can occur if incorrectly installed;
- Attach the furniture to the wall with the fastening provided for this purpose
- Screw and Pegs are not supplied. Use Screws and pegs adapted to the support.

DE

WARNUNG: DAS MÖBEL MUSS AN DER WAND BEFESTIGT WERDEN, UM ZU VERHINDEN DASS ES KIPPT

- Um das Produkt korrekt zu installieren und um Risiken für Ihre Sicherheit zu verhindern, die Gebrauchsanleitung genauestens befolgen.
- Das Möbel mit den vorgesehenen Befestigungen an einer Wand befestigen.
- Schrauben und Dübel sind nicht im Lieferumfang enthalten. Passende Schrauben und Dübel verwenden.

ES

ADVERTENCIA: ESTE MUEBLE DEBE ESTAR SIEMPRE FIJO EN LA PARED PARA EVITAR QUE VUELQUE

- Para instalar correctamente este producto y eliminar los riesgos para la seguridad, seguir exactamente las instrucciones del manual.
- Fijar el mueble a la pared con las sujeciones previstas a este efecto.
- Los tornillos y los tacos no están incluidos. Utilizar tornillos y tacos adaptados al soporte.

NL

WAARSCHUWING: MEUBEL MOET VERPLICHT AAN DE MUUR BEVESTIGD WORDEN ZODAT HET NIET KAN OMVALLEN

- Om dit product correct te installeren en alle risico's voor uw veiligheid te elimineren, gelieve de instructies in deze handleiding nauwgezet op te volgen.
- Zet het meubel vast aan de muur met de hiertoe voorziene bevestigingen.
- De schroeven en pluggen zijn niet meegeleverd. Gebruik schroeven en pluggen die geschikt zijn voor het materiaal van de muur.

IT

AVVERTENZA: MOBILE DA FISSARE IMPERATIVAMENTE AL MURO PER EVITARE CHE SI RIBALTI

- Per installare correttamente questo prodotto ed eliminare i rischi per la vostra sicurezza, si prega di seguire esattamente il manuale d'istruzioni.
- Fissare il mobile al muro con gli appositi ganci.
- Le viti e i tasselli non sono forniti. Utilizzare viti e tasselli adatti al supporto.

PT

ADVERTÊNCIA: MÓVEL A FIXAR OBRIGATORIAMENTE À PAREDE PARA EVITAR A SUA QUEDA

- Para instalar corretamente este produto e eliminar os riscos para a sua segurança, é favor seguir exatamente este manual de instruções.
- Fixe o móvel à parede com as fixações previstas para o efeito
- Os parafusos e as cavilhas não são fornecidos. Utilize parafusos e cavilhas adaptados ao suporte.

PL

OSTRZEŻENIE: MEBEL NALEŻY PRZYMOCOWAĆ DO ŚCIANY, ABY UNIKNĄĆ JEGO PRZEWRÓCENIA

- Aby prawidłowo zainstalować ten produkt i wyeliminować zagrożenie dla bezpieczeństwa użytkownika, należy postępować zgodnie z niniejszą instrukcją.
- Przymocować mebel do ściany za pomocą mocowań przewidzianych w tym celu.
- Śruby i nakrętki nie znajdują się w zestawie. Użyć śrub i nakrętek dostosowanych do wspornika.

CR

UPOZORENJE : UČVRSTITE ORMARIĆ NA ZID KAKO BISTE SPRIJEČILI NJEGOVO LJULJANJE

- Kako biste pravilno postavili ovaj proizvod i uklonili sigurnosne rizike kojima se izlažete, pridržavajte se strogo ovog priručnika s uputama.
- Postavite ormarić na zid pripadajućim sponama.Vijci i svornjci ne isporučuju se. Upotrijebite nosne vijke i svornjke.

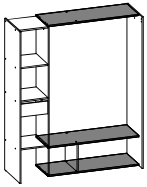

1

C x6

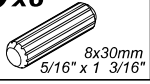

x3

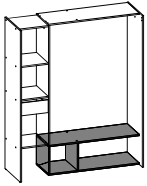
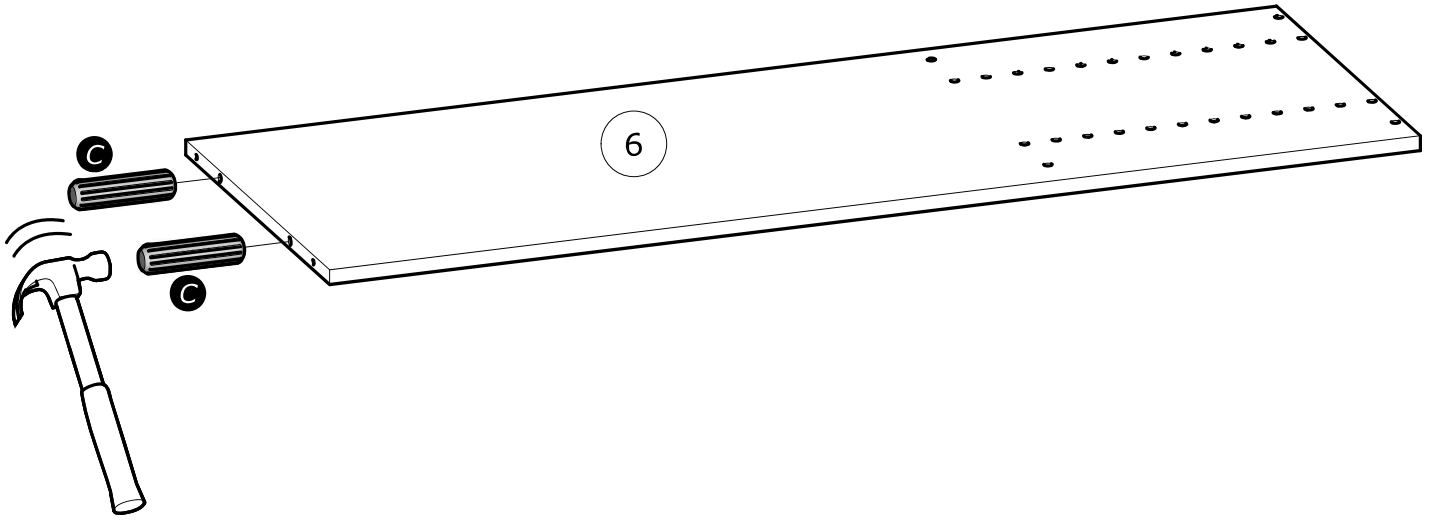





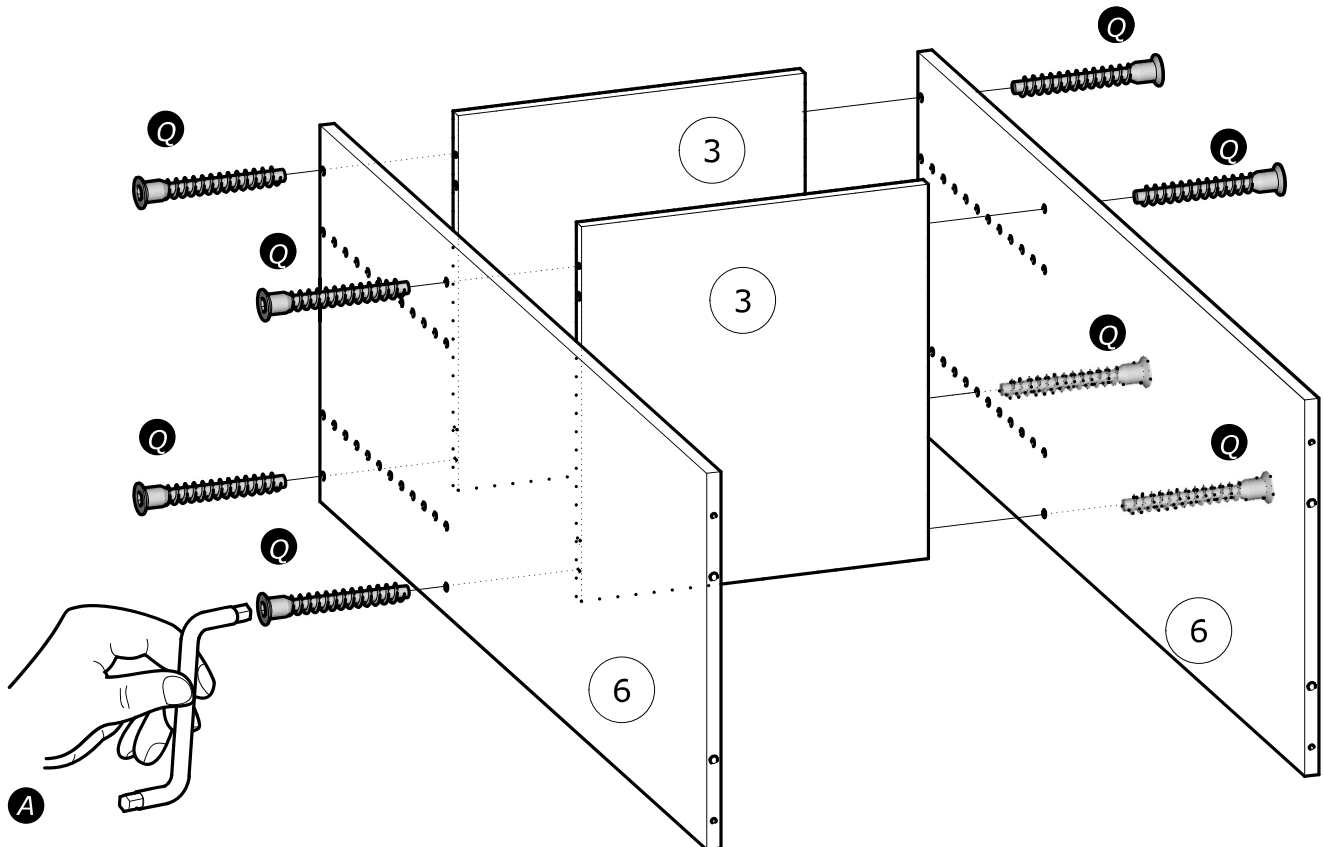
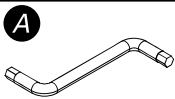
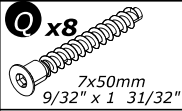

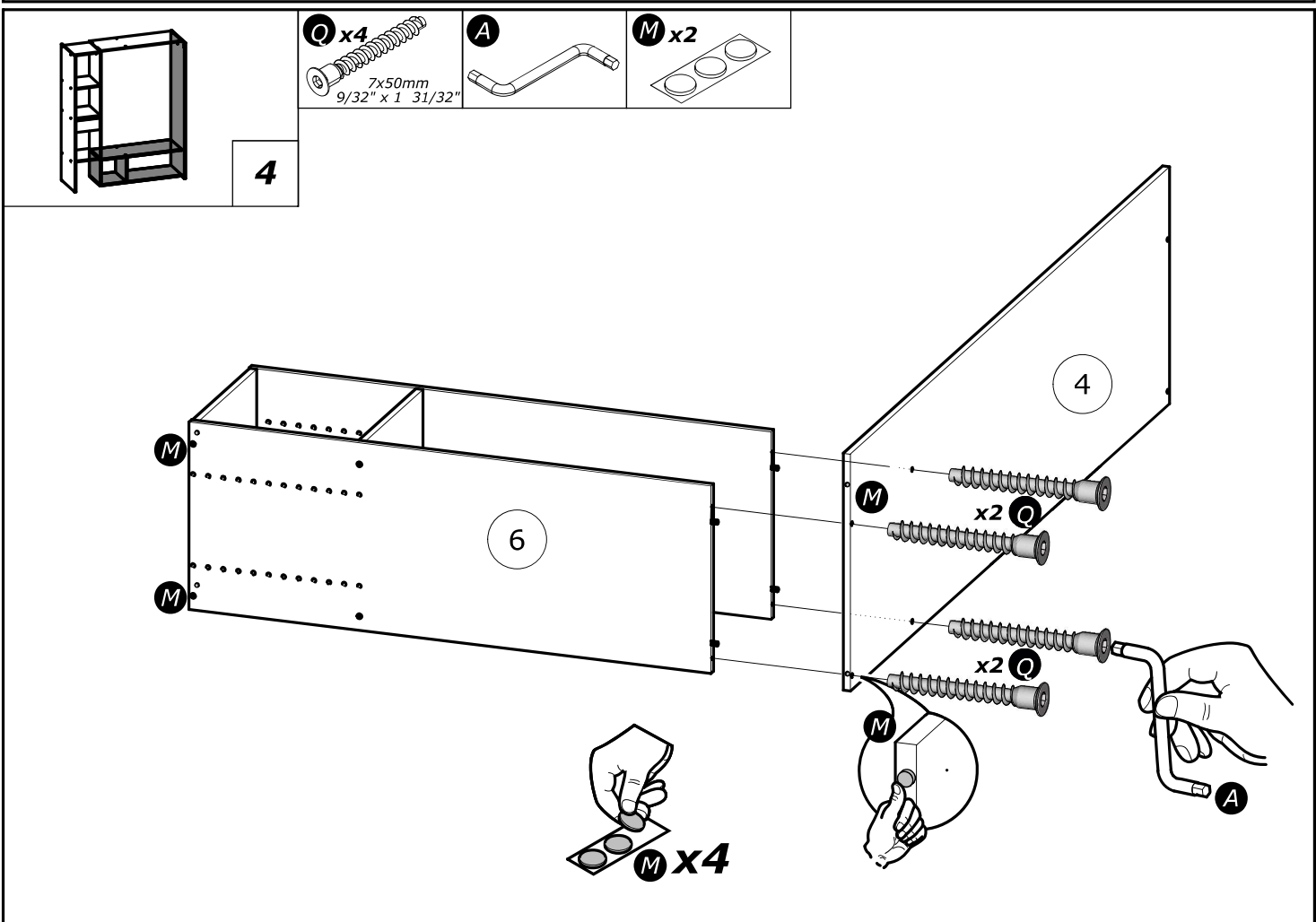
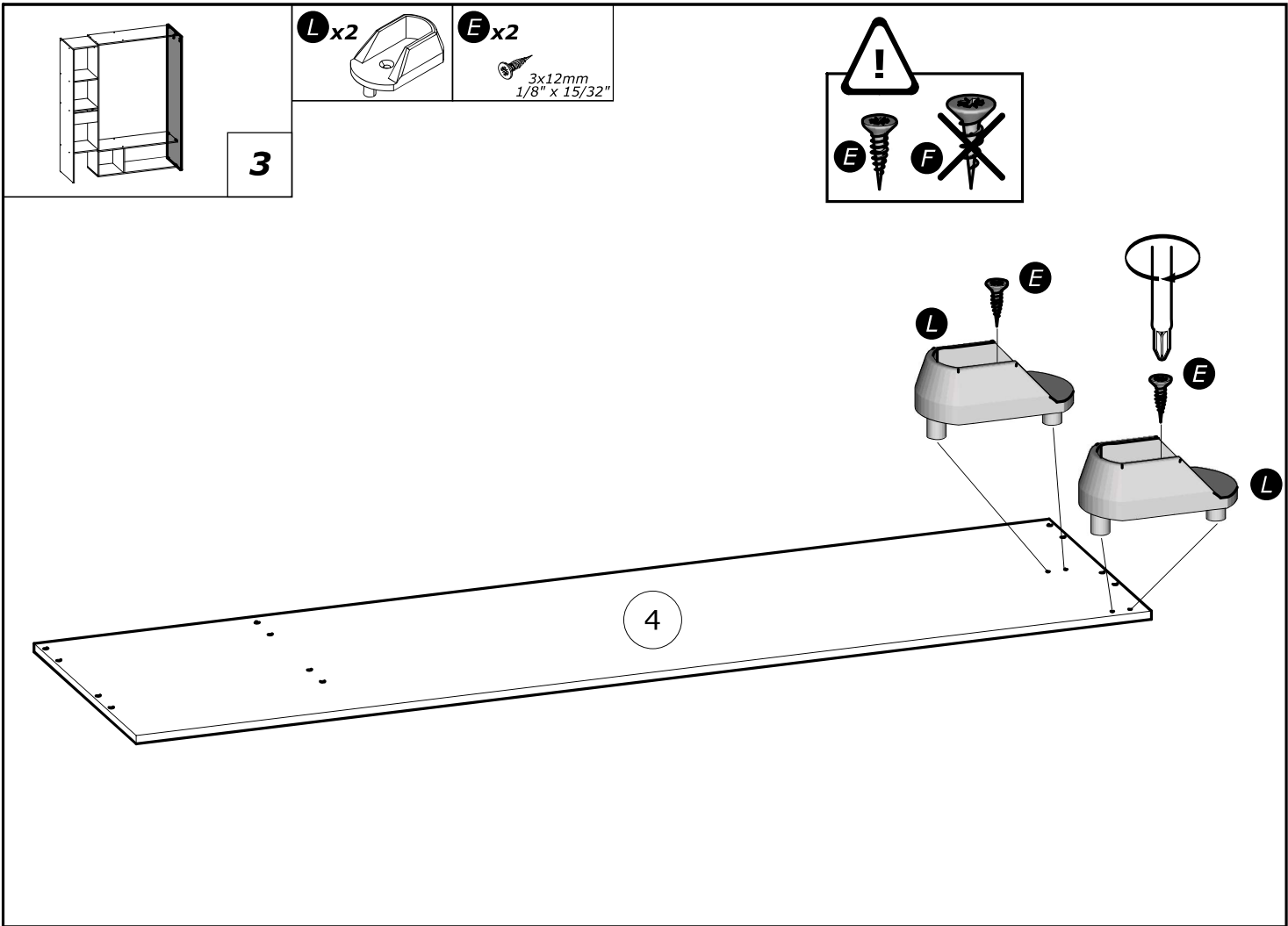

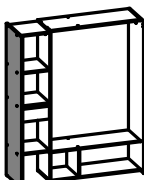
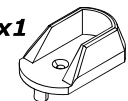
2

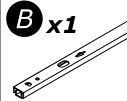

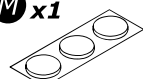

Q x8





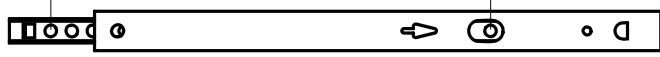

	L x1 	E x1  3x12mm 1/8" x 15/32"	B x1 	D x2  6.3x9mm 1/4" x 11/32"
	5	M x1 		



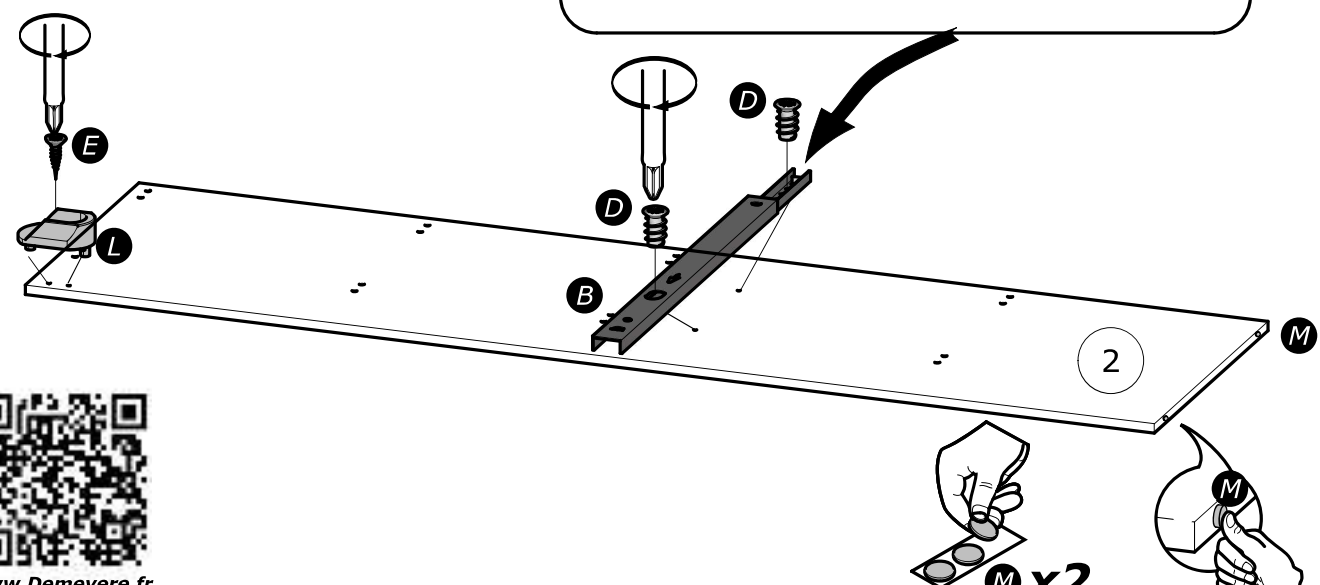







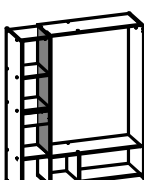
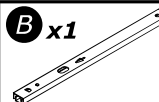



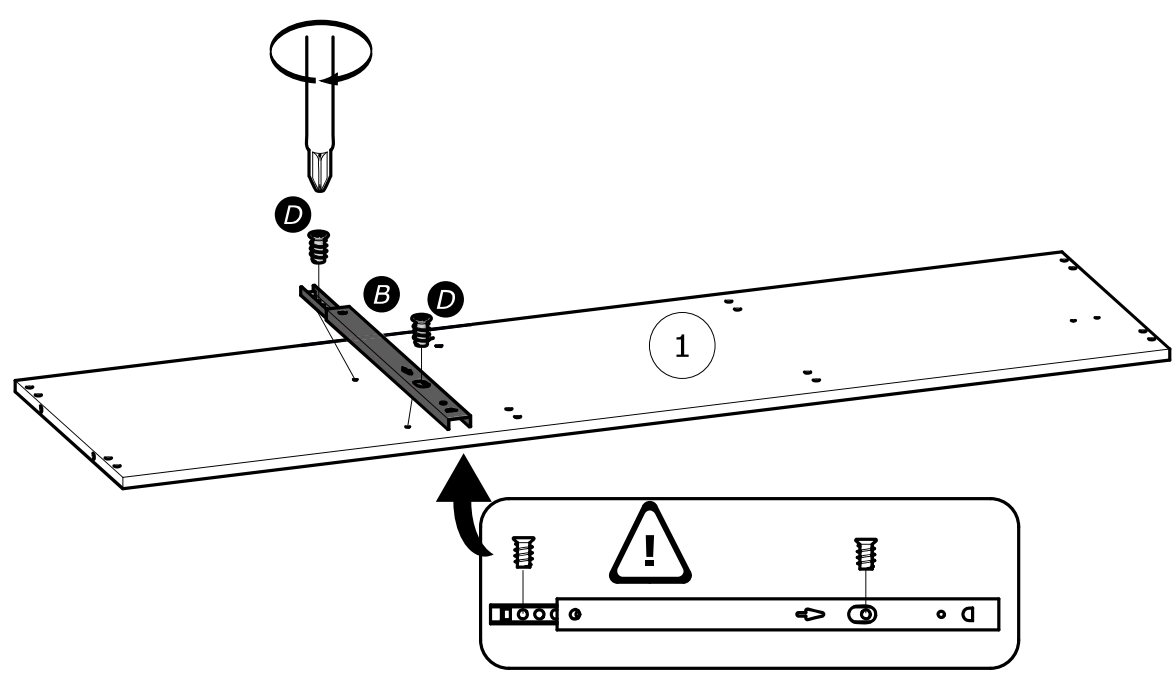

www.Demeyere.fr

	B x1 	D x2  6.3x9mm 1/4" x 11/32"
	6	



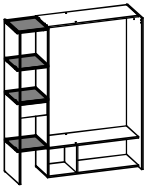

7

C x16

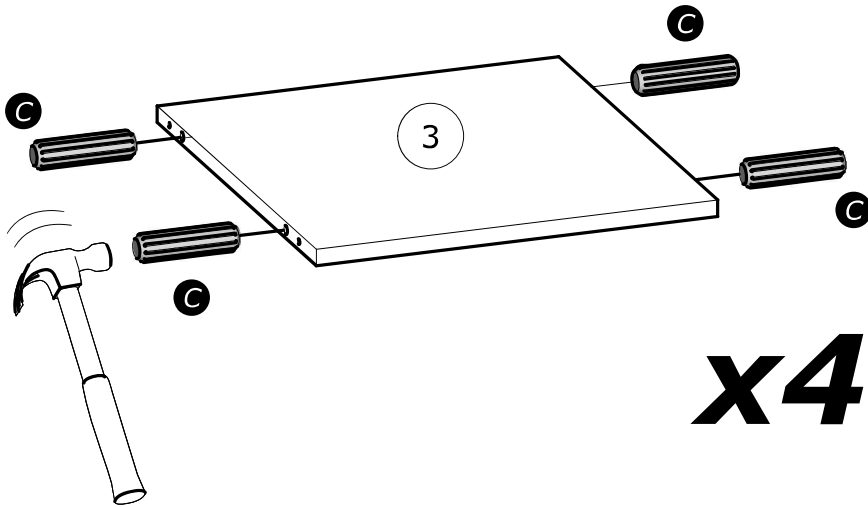
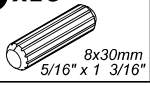

x4

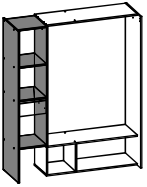

8

Q x8

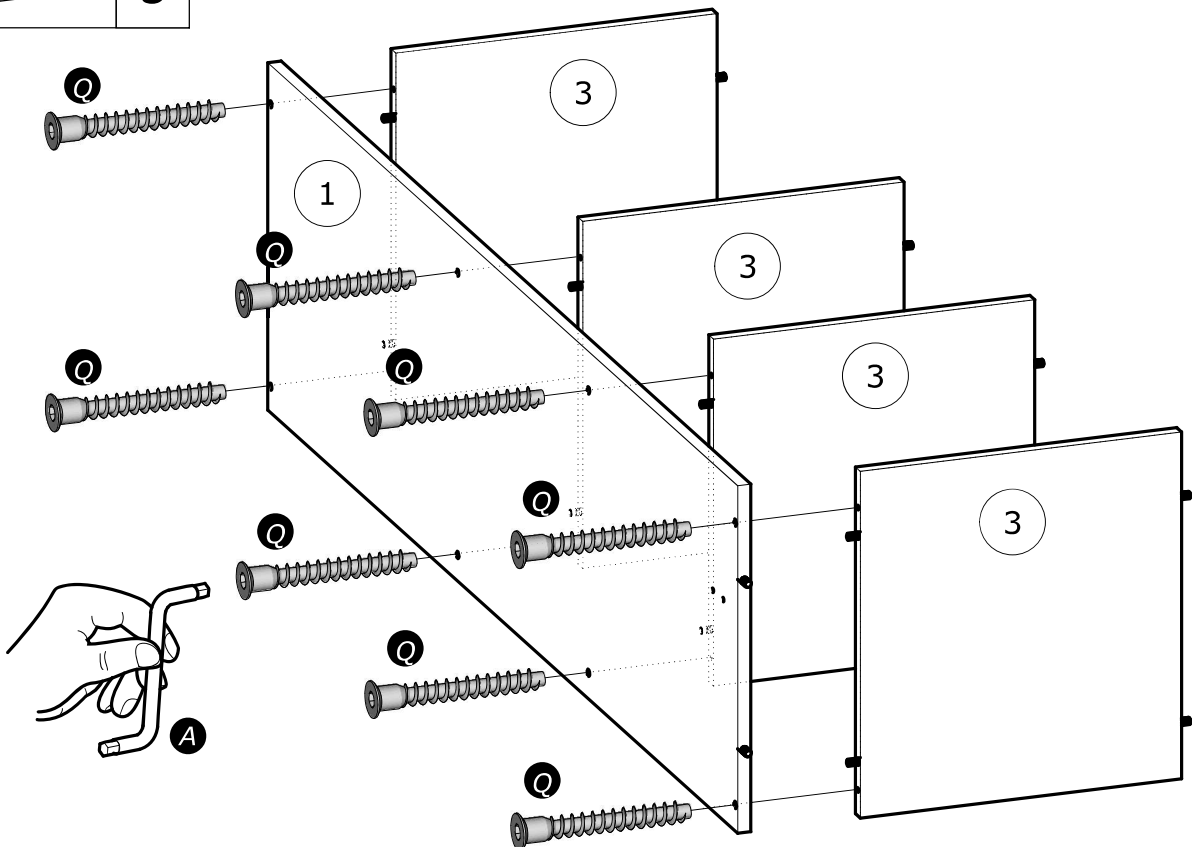
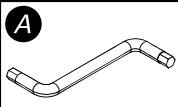
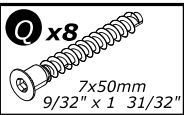

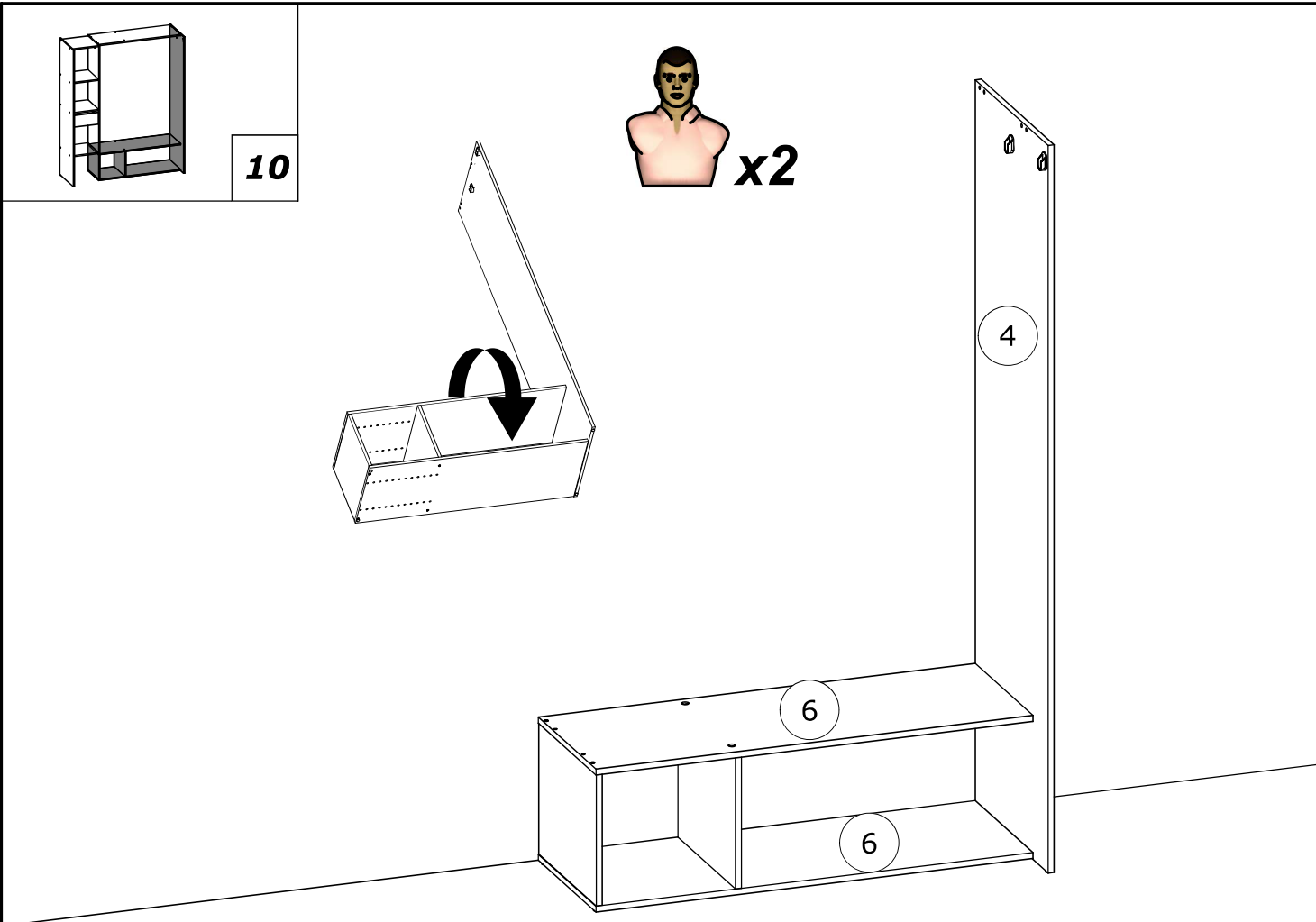
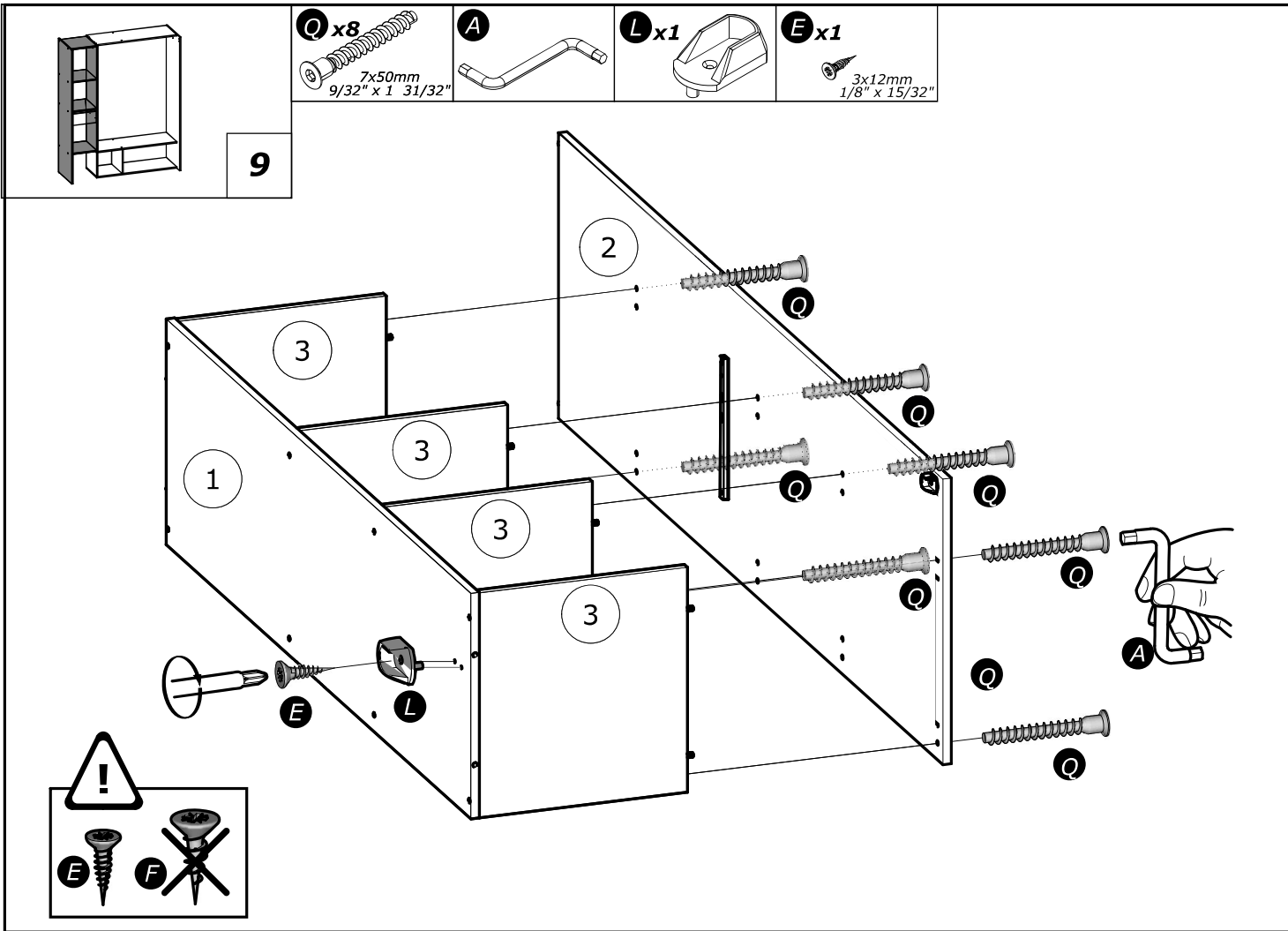

A

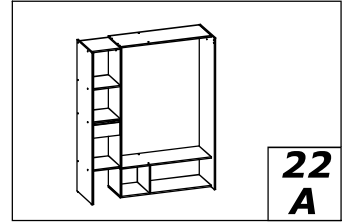
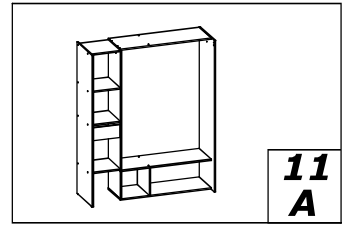
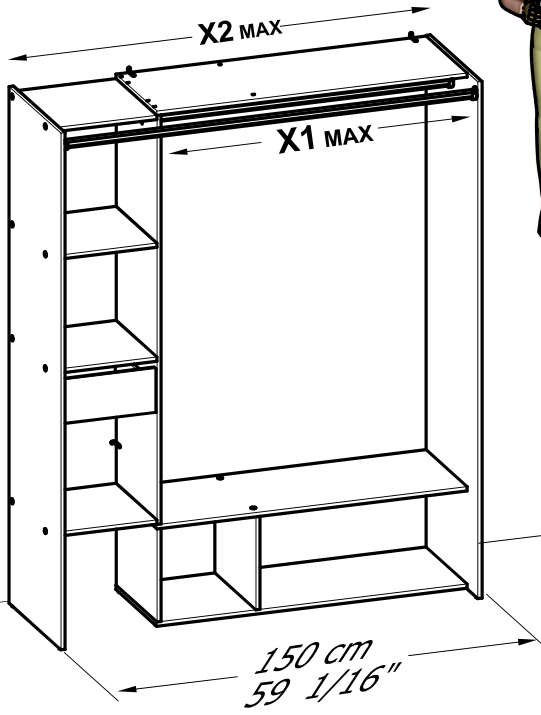
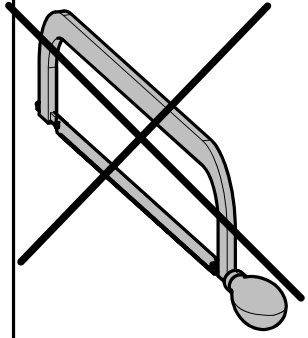

B

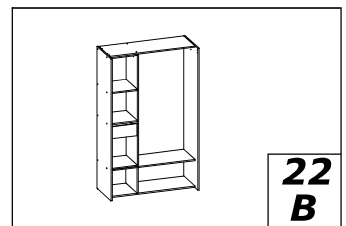
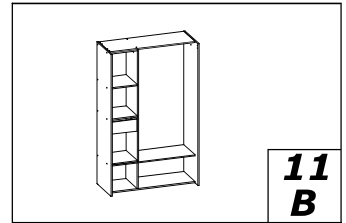
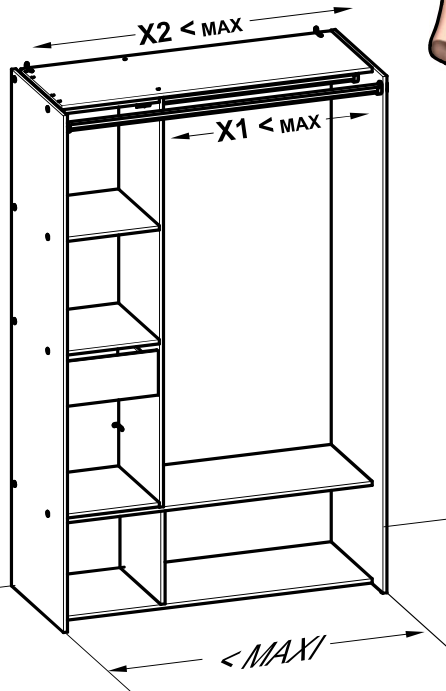
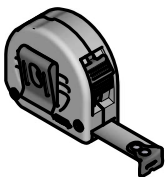
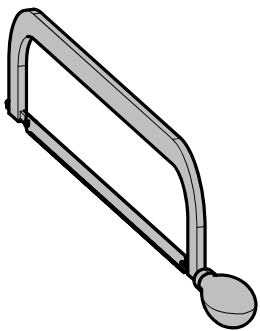

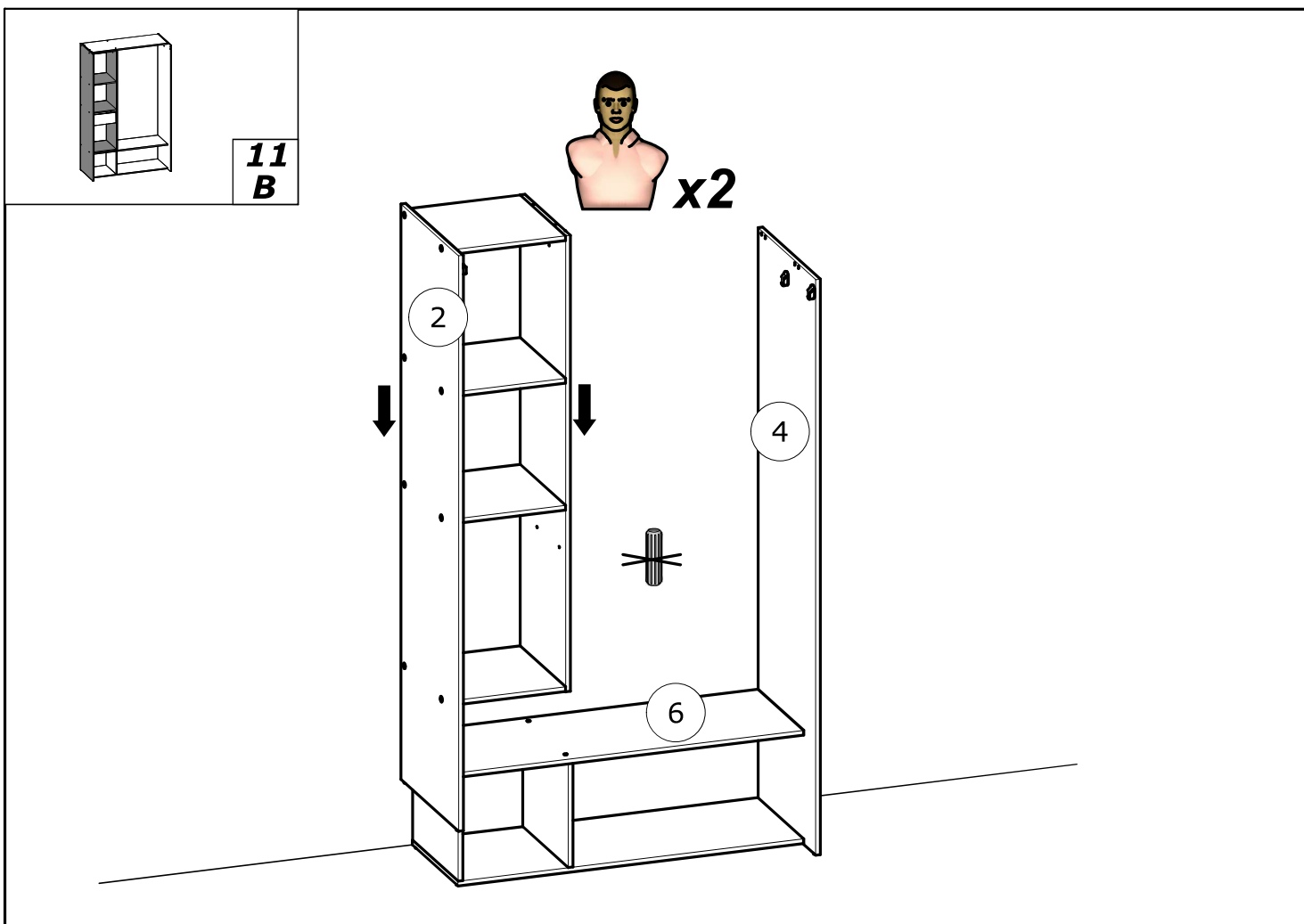
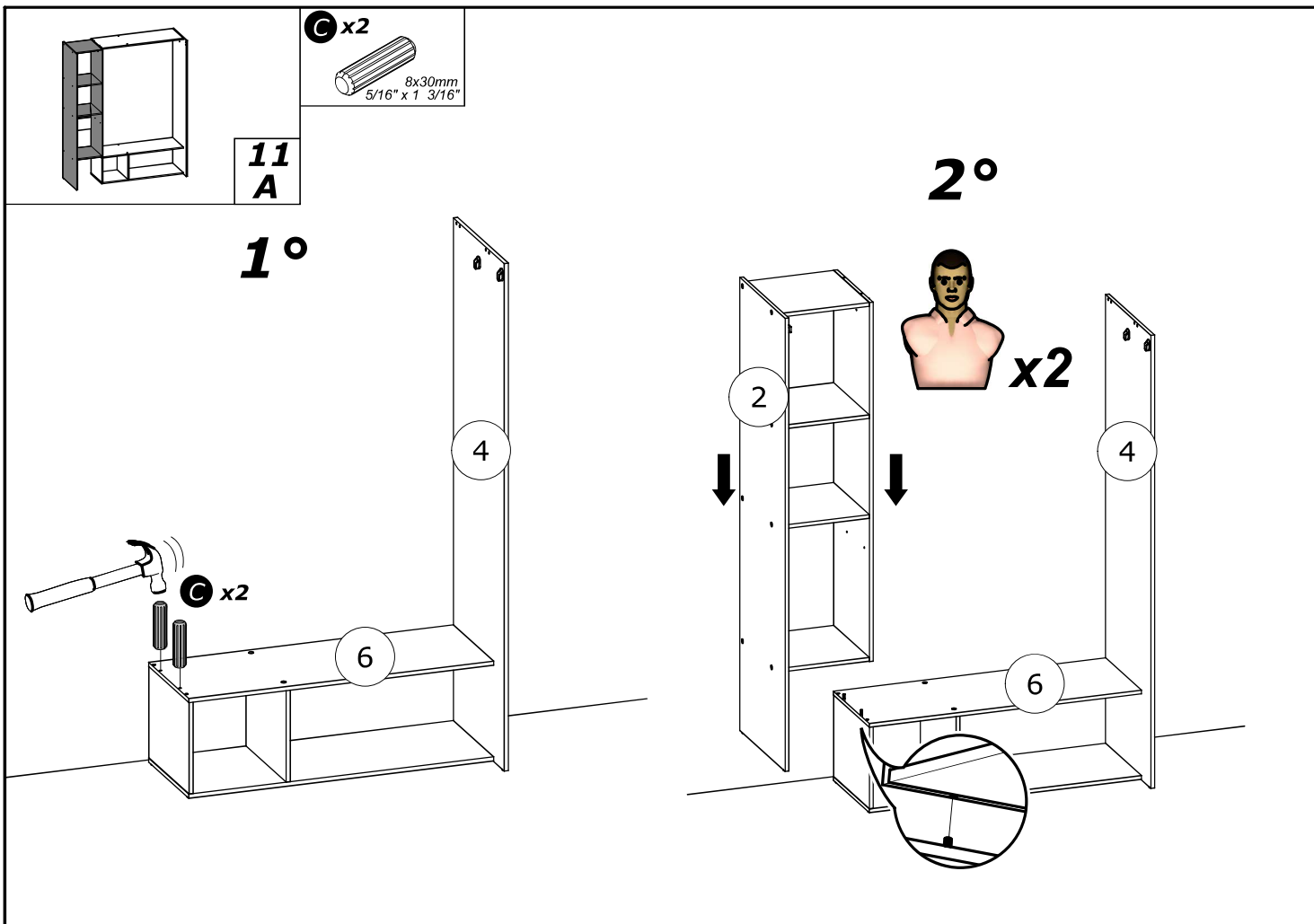

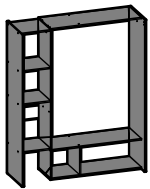

12
A&B

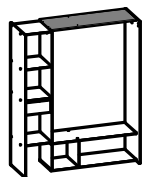
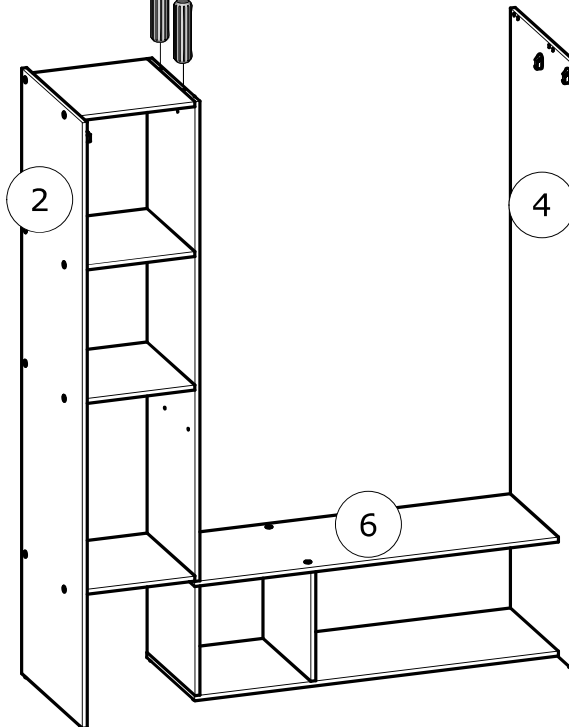
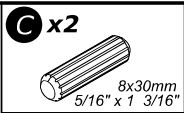

13
A

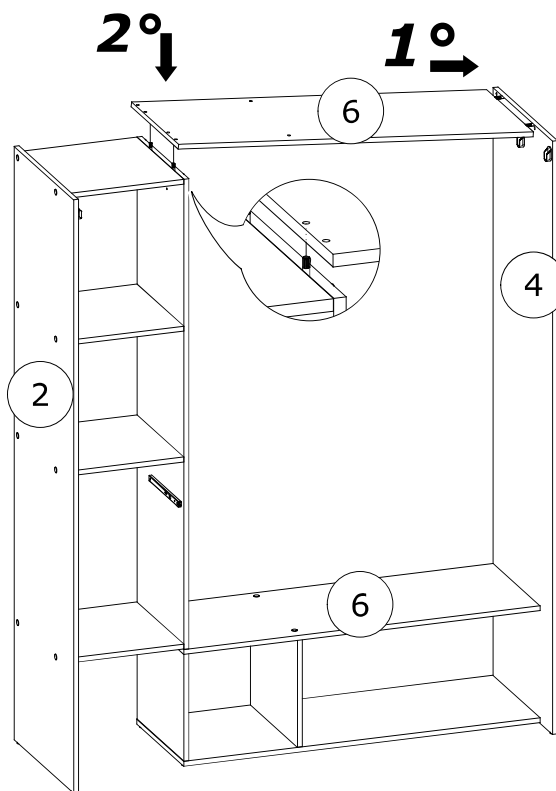
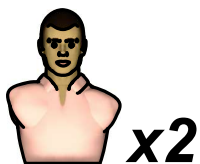

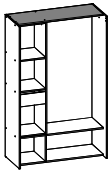

13
B

2° ↓ 1° →

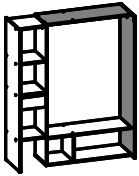
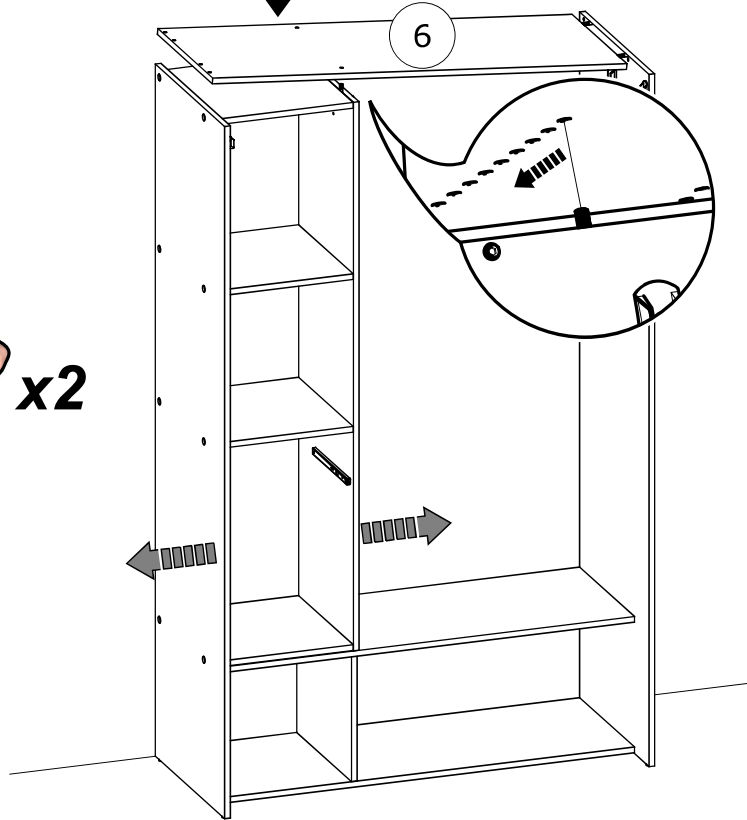
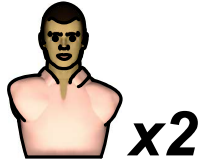

14
A&B

Q x2
7x50mm
9/32" x 1 31/32"

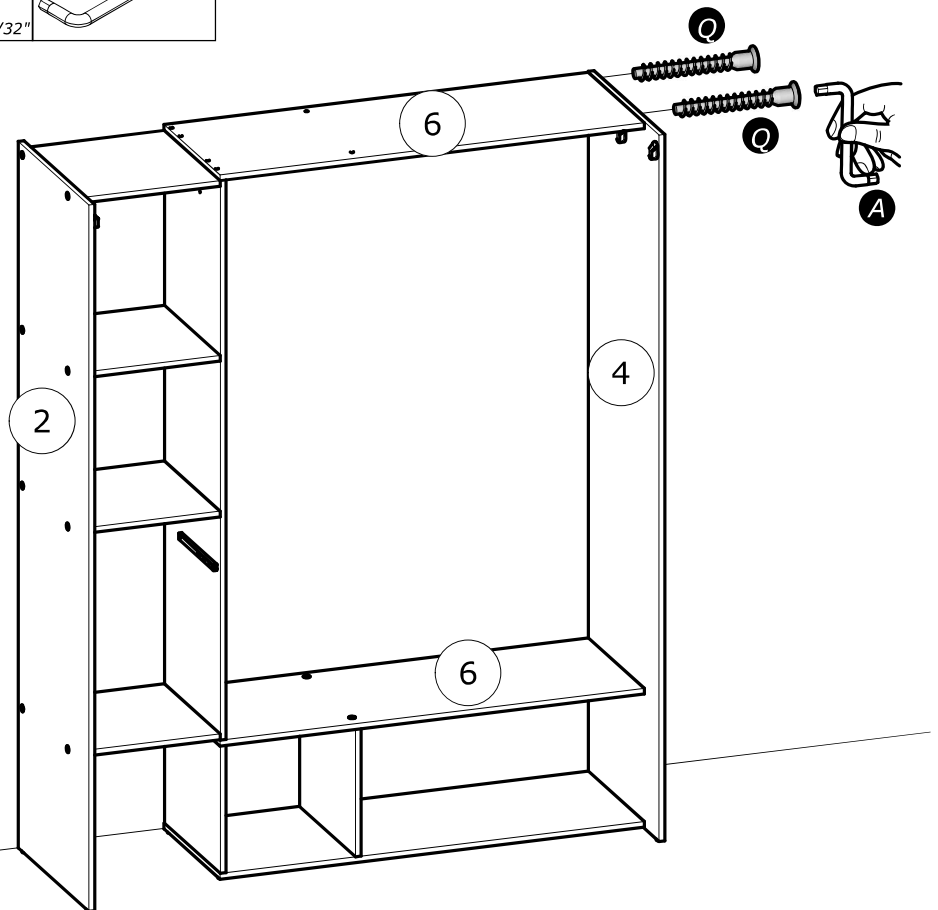
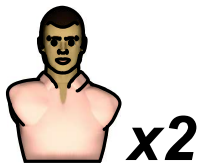
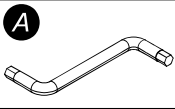

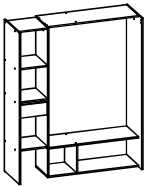

F x3

3.5x15mm
1/8" x 19/32"

N x3

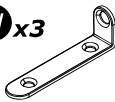

15
A&B

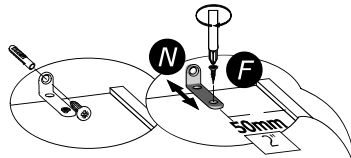
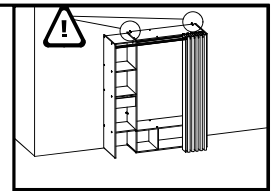

N + F

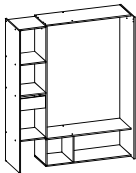
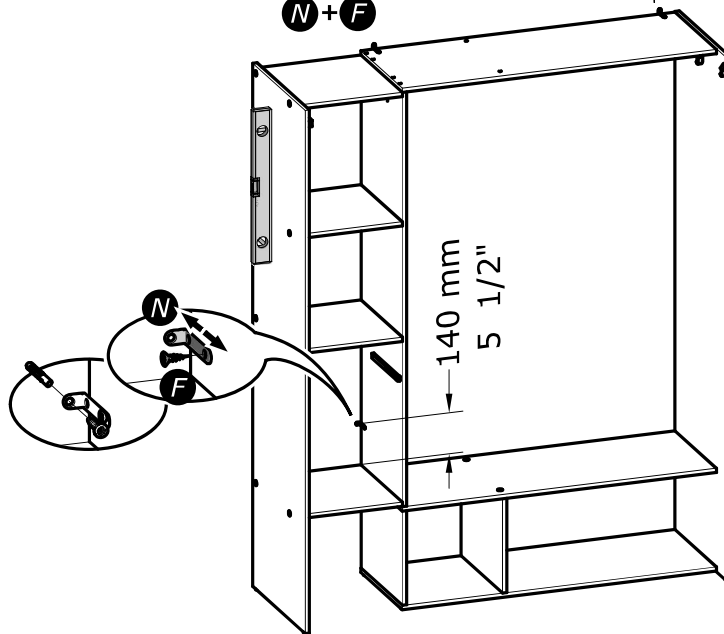

H x24



16
A&B

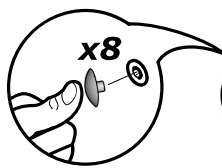

x8

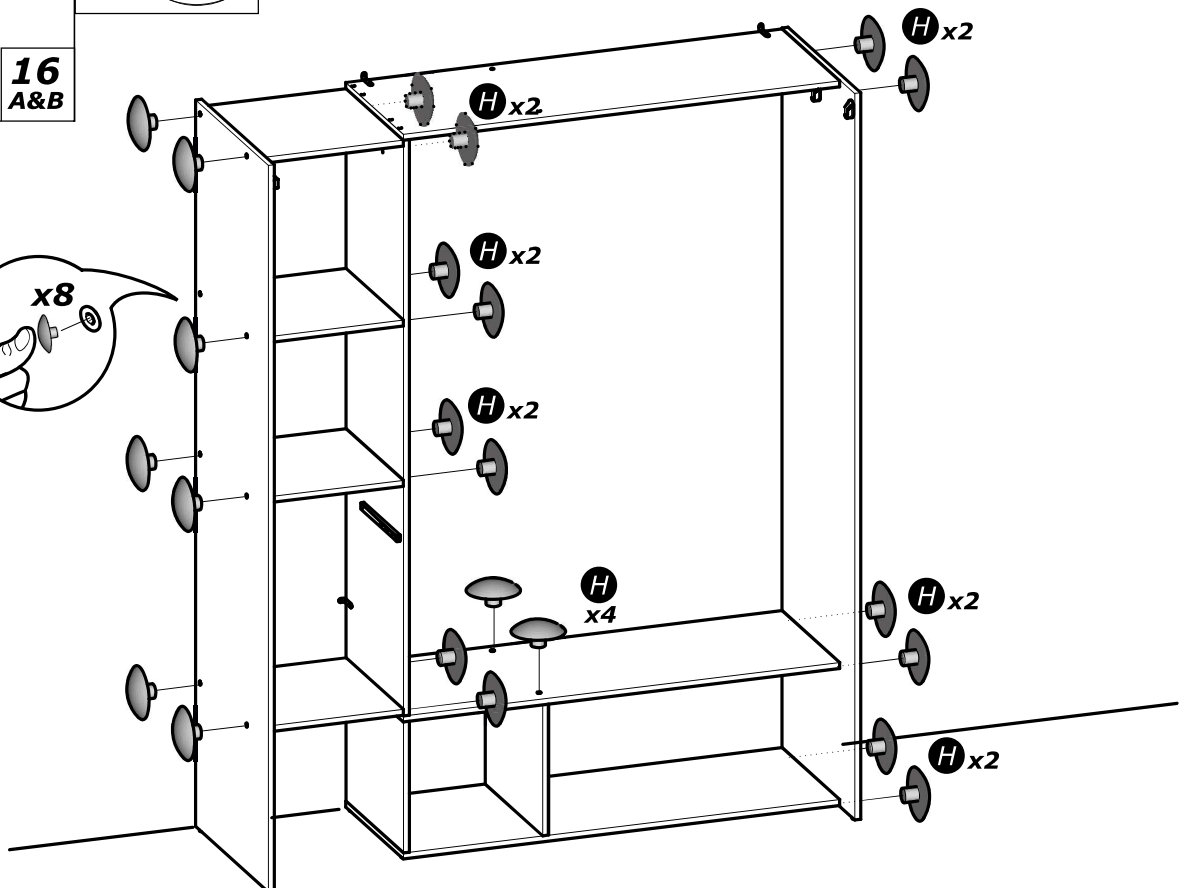

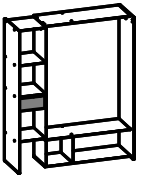

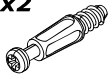
J x2

17
A&B

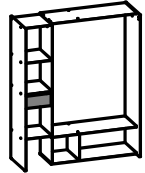
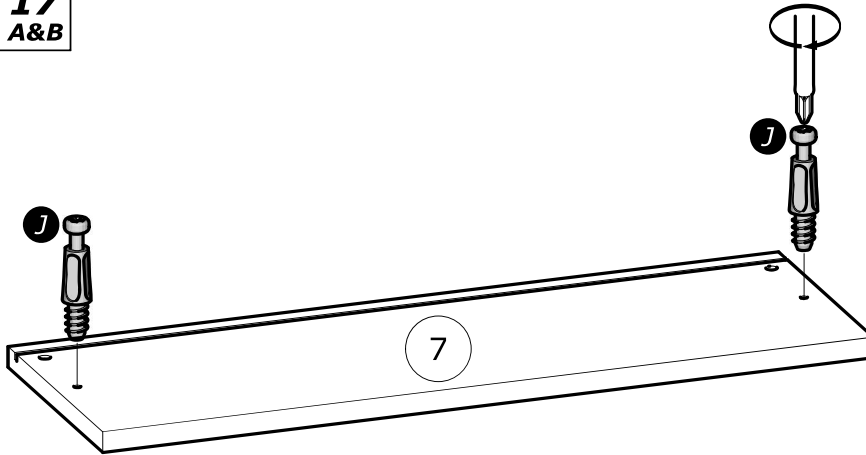

R x2
 Ø12mm
Ø15/32"

18
A&B

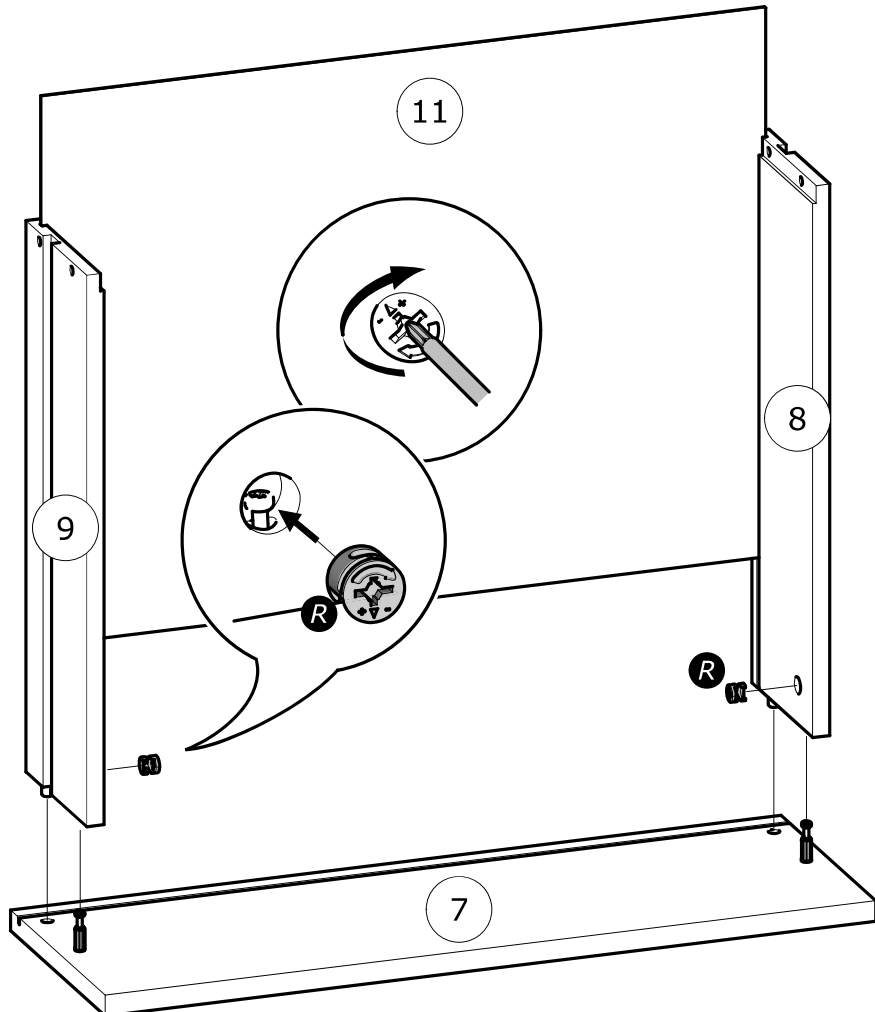

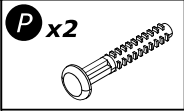
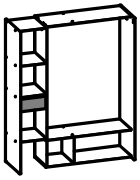

19
A&B

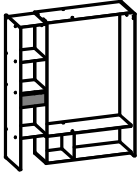
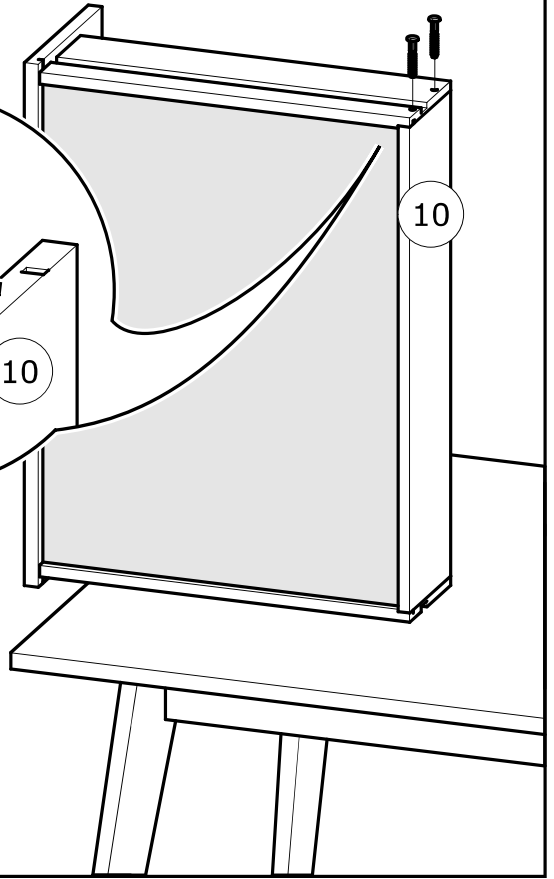
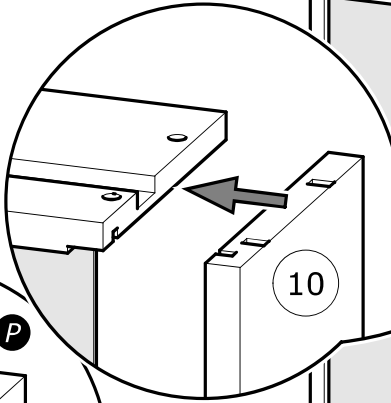
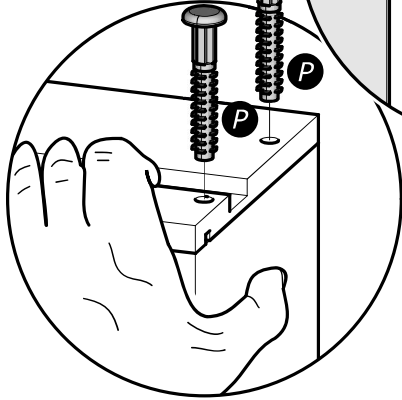
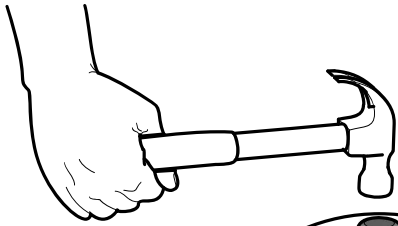

20
A&B

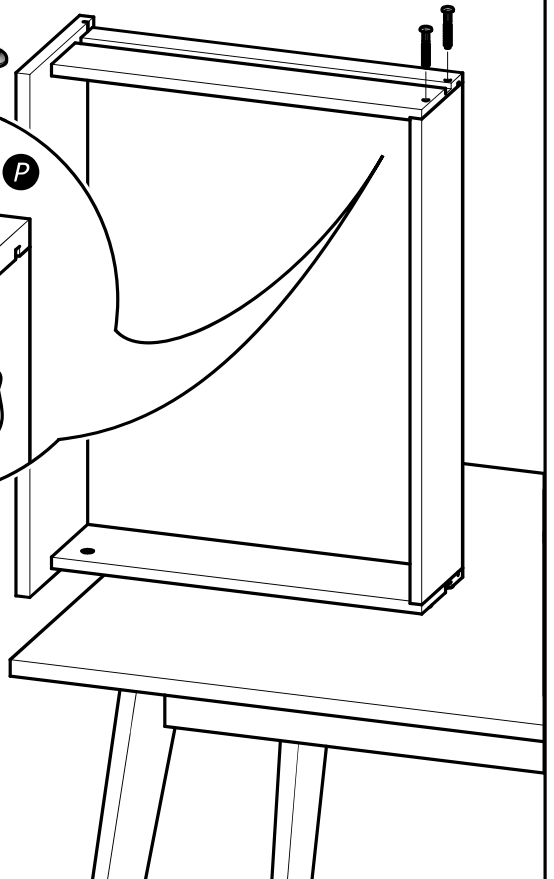
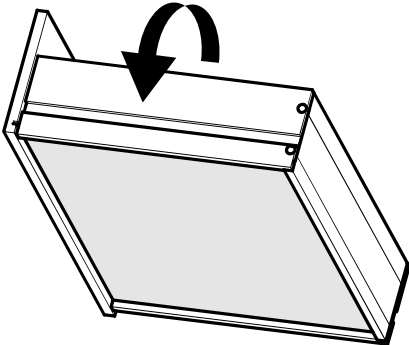
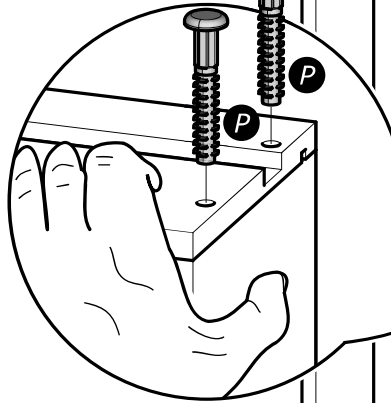
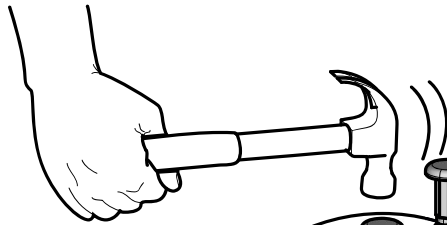
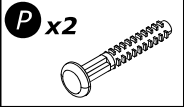

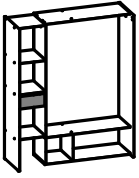

G x2
4x9mm
5/32" x 11/32"

21
A&B



www.Demeyere.fr

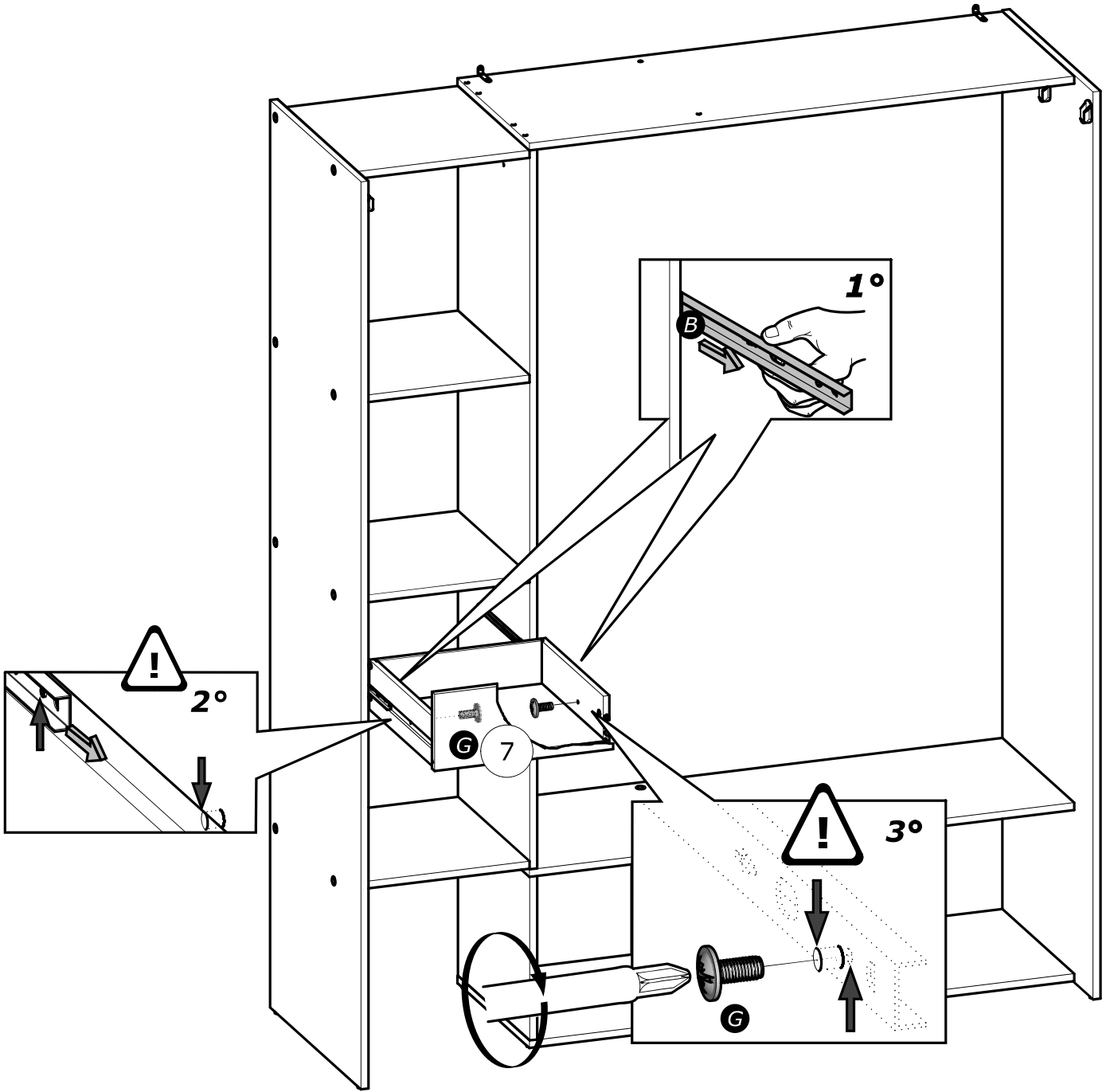

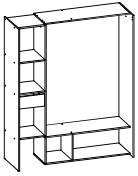

22
A

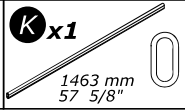
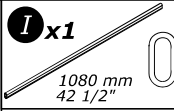

X1 Max

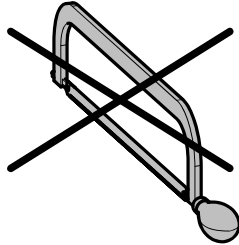
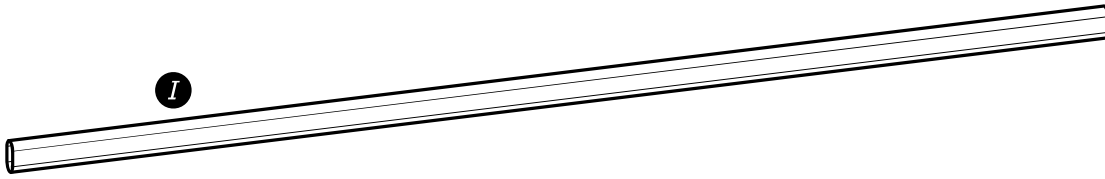

X2 Max

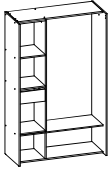
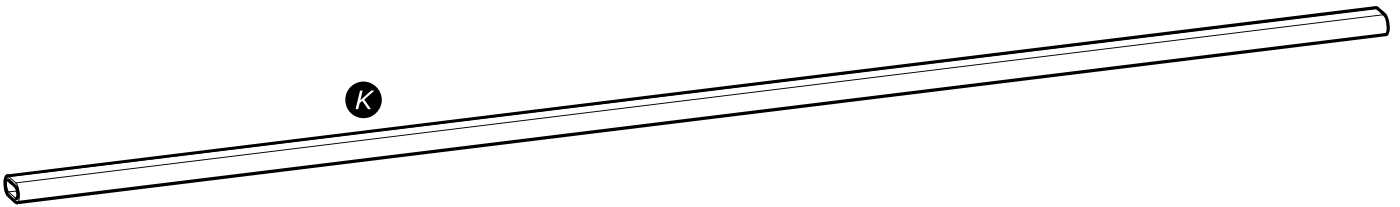

22
B

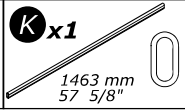
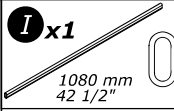

X1 < Max

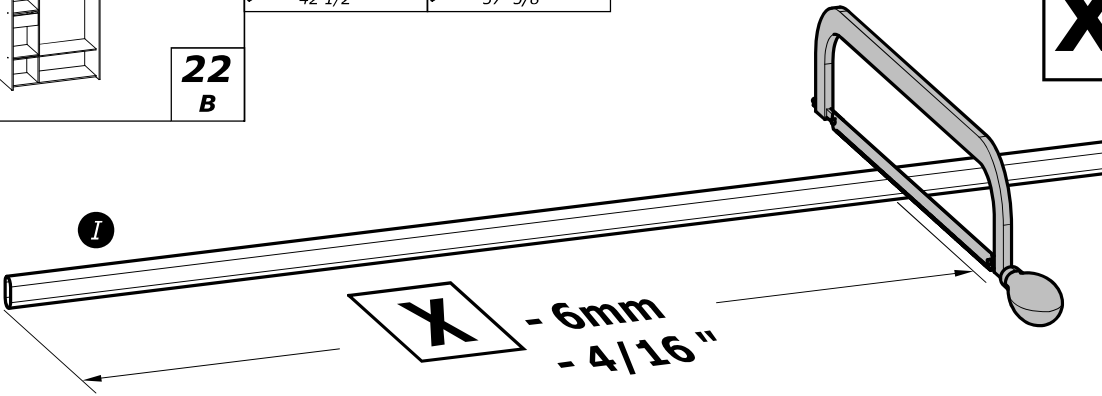

X2 < Max

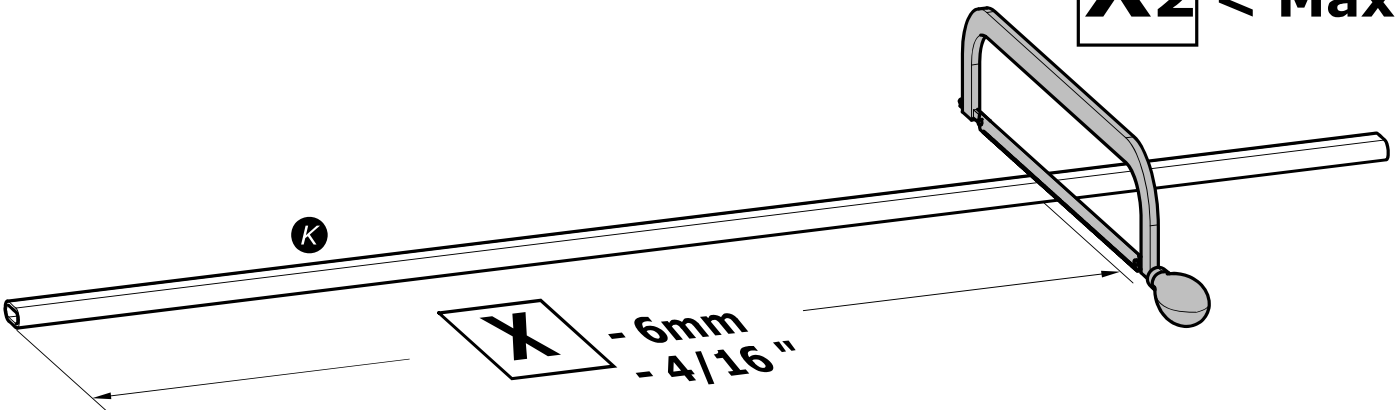

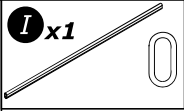
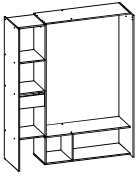

23
A&B

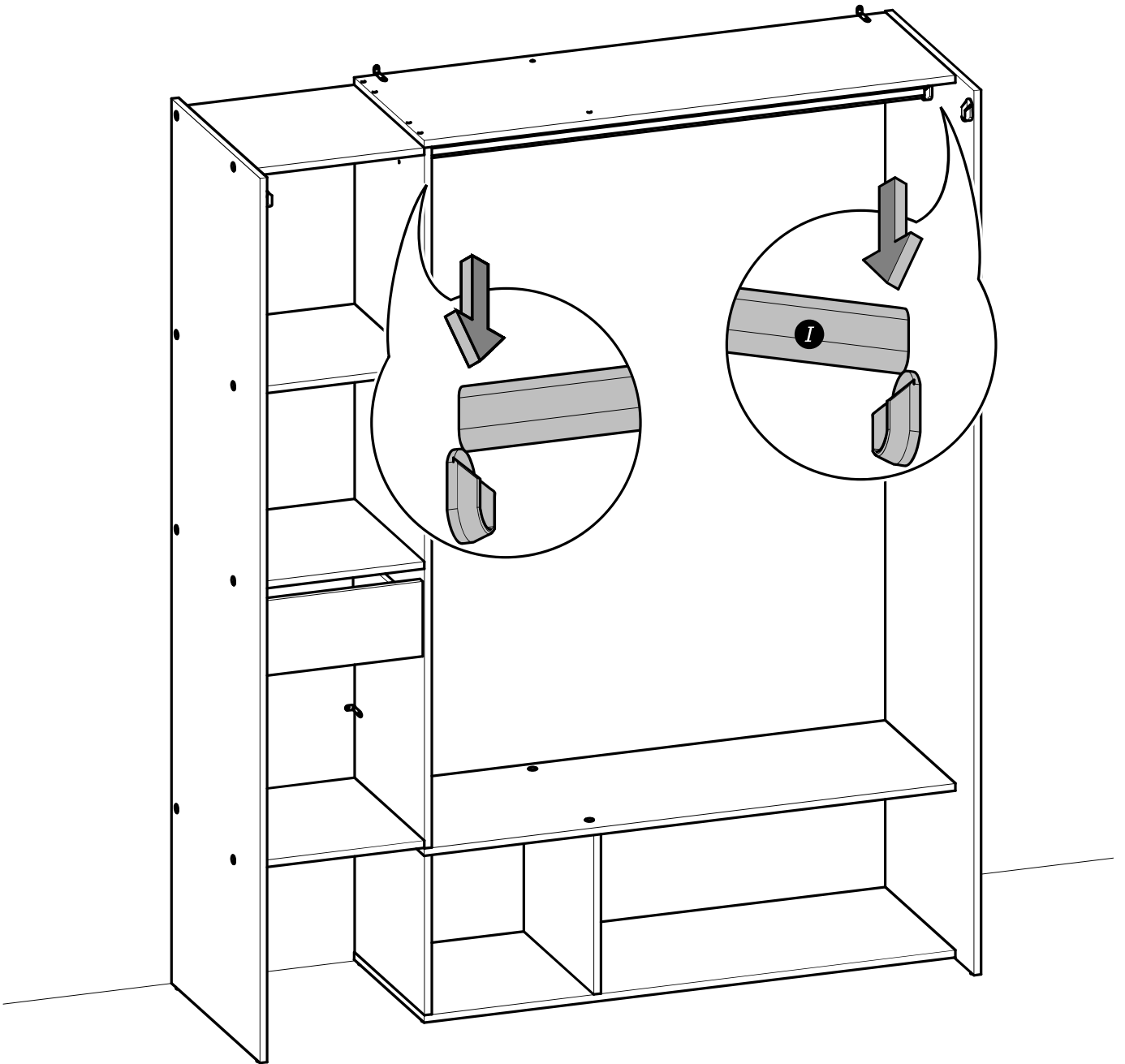

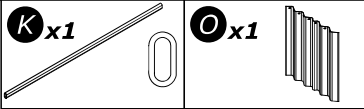
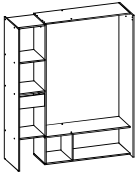

24
A&B

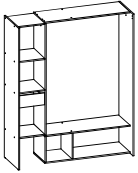
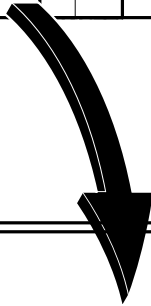
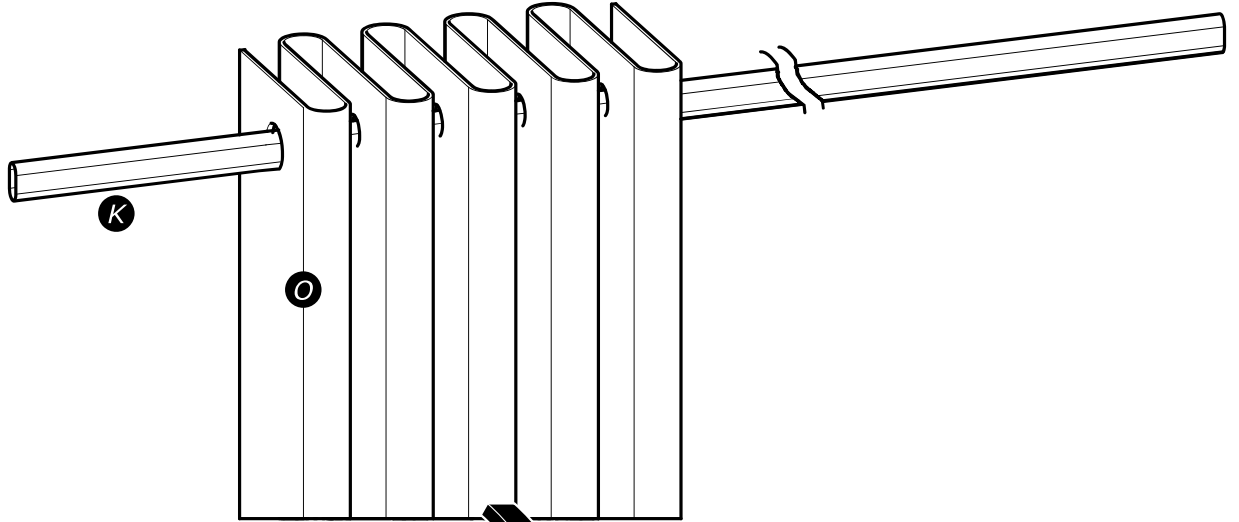

25
A&B

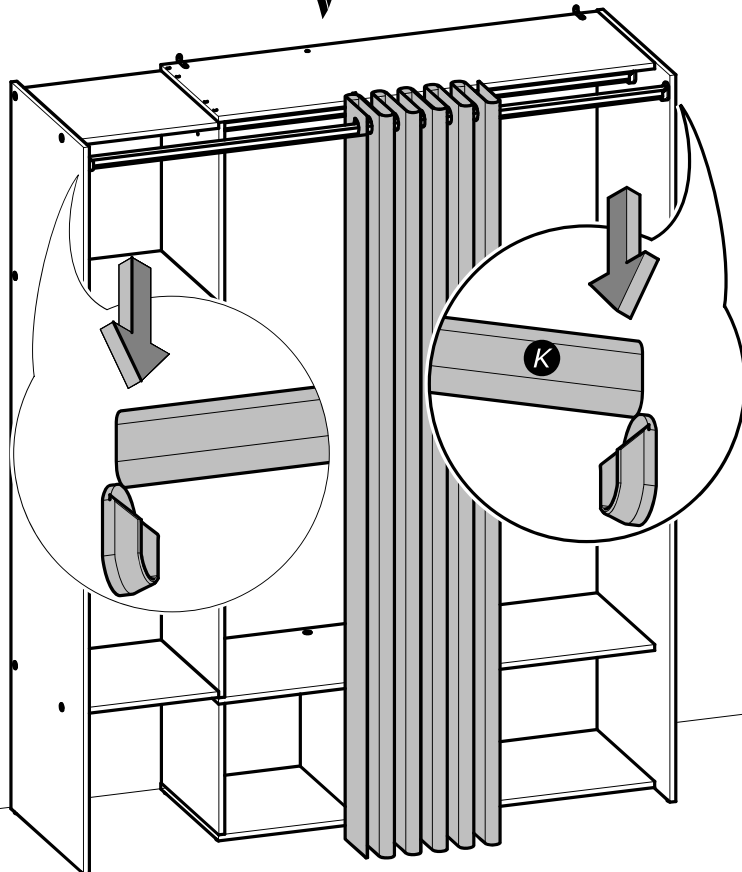

Info tri déchets

www.quefairedemesdechets.fr