

NOTICE DE MONTAGE

INSTALLATION INSTRUCTIONS

MOONLIGHT

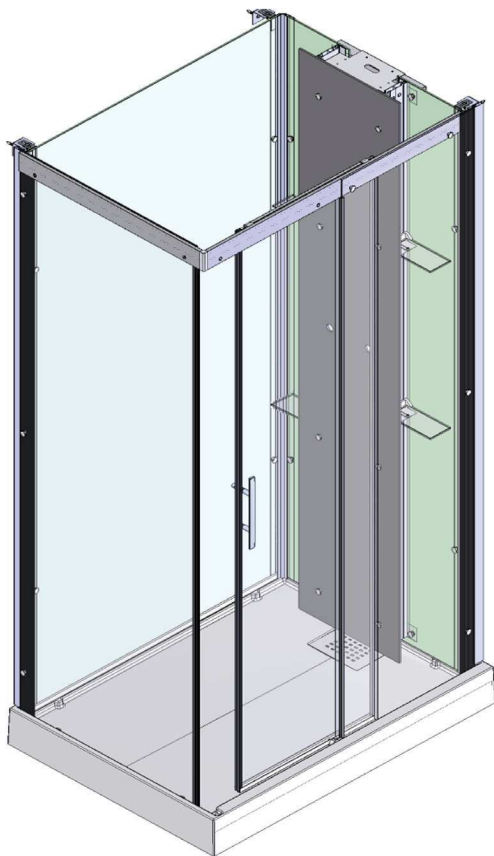

DES847H

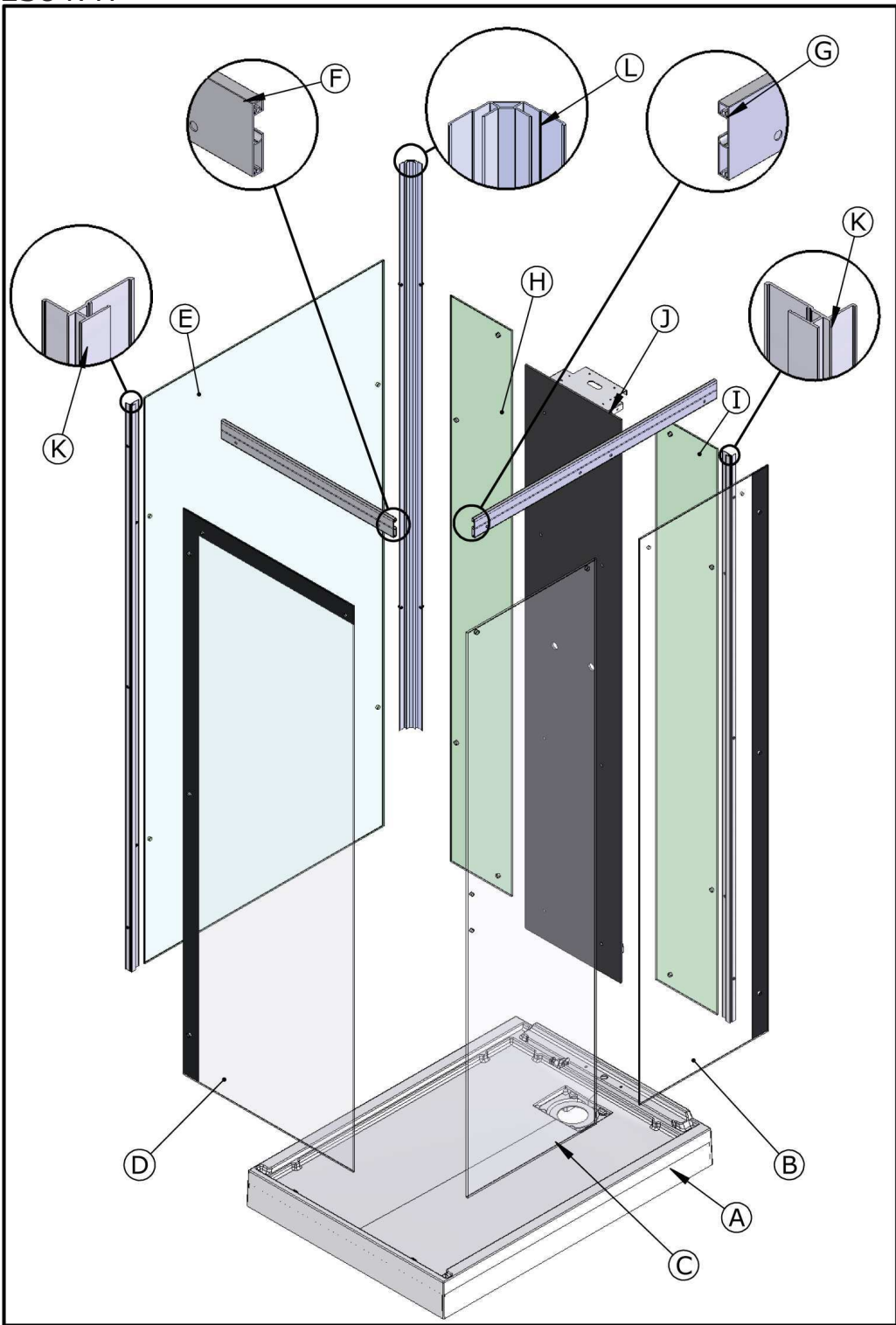



CODE COLIS (Voir repères P.2)
BOX CODES (See marks P.2)

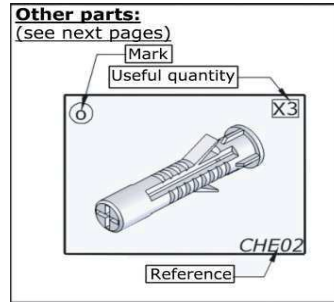
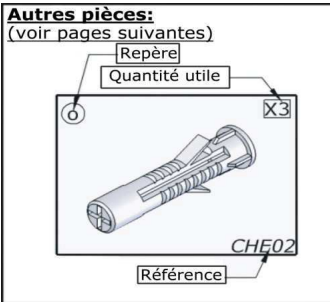



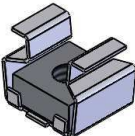
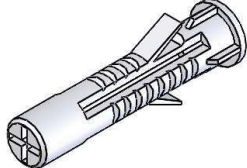
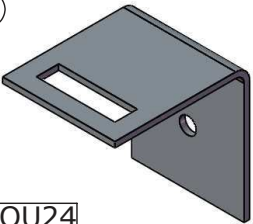
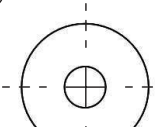
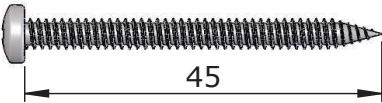
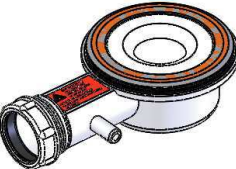
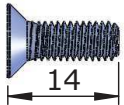
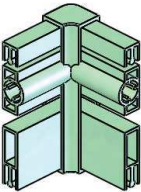
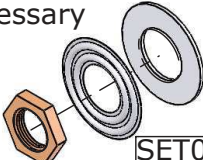
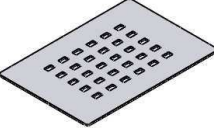

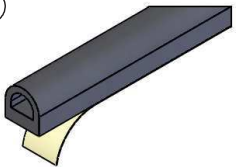
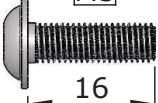
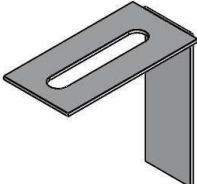
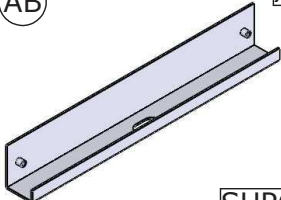
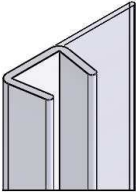

REP	110x80	120x90
A	REC206	REC226
B+C	C5513E	C6535E
D	C5512	C6517E
E	C4852	C6499E
F+G	5902	5902
H+I	C7202	C7215
J	CP851	CP851
K	5934	5934
L	5933	5933

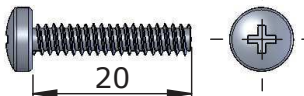
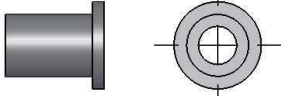
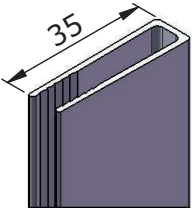
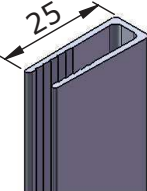
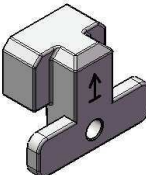
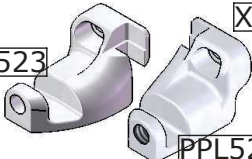
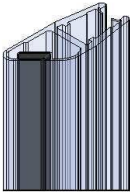
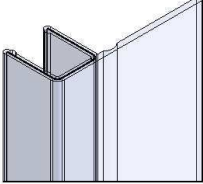

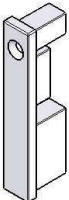
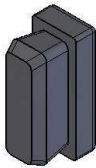
DES847H

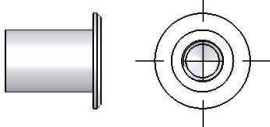

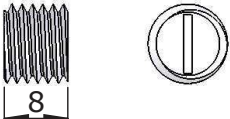
<p>(M) X3</p>  <p>ECR46</p>	<p>(N) X3</p>  <p>CHE02</p>	<p>(O) X3</p>  <p>EQU24</p>
<p>(P) X6</p>  <p>1=1</p> <p>RON51</p>	<p>(Q) X3</p>  <p>Ø3.9</p> <p>45</p> <p>1=1</p> <p>VIS17</p>	
<p>(R) X1</p>  <p>BOND16</p>	<p>(S) M5 X4</p>  <p>14</p> <p>1=1</p> <p>VIS159</p>	<p>(T) X1</p>  <p>PPL353</p>
<p>(U) X2</p> <p>Si nécessaire If necessary</p>  <p>SET01</p>	<p>(V) X1</p>  <p>TOL11</p>	<p>(W) X22</p>  <p>ENT19</p>
<p>(X) X18</p>  <p>M5</p> <p>20</p> <p>1=1</p> <p>VIS10</p>	<p>(Y) X2</p>  <p>LG=2000mm</p> <p>J446</p>	<p>(Z) X3</p>  <p>M5</p> <p>16</p> <p>1=1</p> <p>VIS195</p>
<p>(AA) X3</p>  <p>EQU50</p>	<p>(AB) X2</p>  <p>SUP63</p>	<p>(AC) X1</p>  <p>LG=1997mm</p> <p>J443</p>

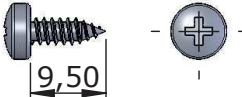
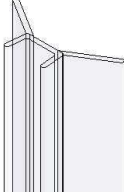
Les quantités données sont les quantités utiles au montage. Les sachets fournis contiennent des pièces supplémentaires.
The quantities given are what are required for the installation. There may be some surplus parts in the package provided.

<p>(AD) M4 X3</p>  <p>20</p> <p>1=1 VIS09</p>	<p>(AE) X3</p>  <p>1=1 ECR14</p>	<p>(AF) X1</p>  <p>35</p> <p>PFL42</p>
<p>(AG) X1</p>  <p>25</p> <p>PFL43</p>	<p>(AH) X1</p>  <p>PPL550</p>	<p>(AI) X1</p>  <p>PPL523</p> <p>PPL522</p> <p>Utiliser une des deux pièces suivant le sens de montage</p> <p>Use one of it depending the assembly</p>
<p>(AJ) X1</p>  <p>LG=1925mm</p> <p>AI051</p>	<p>(AK) X1</p>  <p>LG=1925mm</p> <p>J418</p>	<p>(AL) X2</p>  <p>Ø3.5</p> <p>9,50</p> <p>1=1 VIS22</p>
<p>(AM) X2</p>  <p>PPL520</p>	<p>(AN) X1</p>  <p>BUT22</p>	<p>(AO) X22</p>  <p>CAP07</p>
<p>(AP) X4</p>  <p>1=1 ECR31</p>	<p>(AQ) X4</p>  <p>CAP15</p>	<p>(AR) M10 X1</p>  <p>8</p> <p>1=1 VIS07</p>
<p>(AS) X1</p>  <p>BUT20</p>	<p>(AT) X4</p>  <p>Ø3.5</p> <p>9,50</p> <p>1=1 VIS01</p>	<p>(AU) X2</p>  <p>LG=1970mm</p> <p>J540</p>

Les quantités données sont les quantités utiles au montage. Les sachets fournis contiennent des pièces supplémentaires. The quantities given are what are required for the installation. There may be some surplus parts in the package provided.

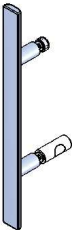
DES847H

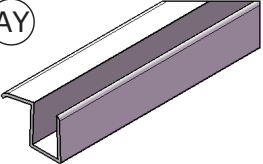
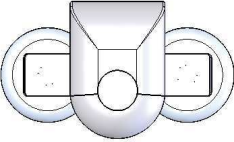
 <p>AV X4</p> <p>VER2161</p>	 <p>AW X1</p> <p>S0948</p>	 <p>AX X1</p> <p>LG=1982mm AI053</p>
 <p>AY X1</p> <p>110x80:LG=523mm J459</p> <p>120x90:LG=568mm J588</p>	 <p>AZ X2</p> <p>ROU21</p>	

Les quantités données sont les quantités utiles au montage. Les sachets fournis contiennent des pièces supplémentaires.
 The quantities given are what are required for the installation. There may be some surplus parts in the package provided.

Matériel nécessaire

Tools required

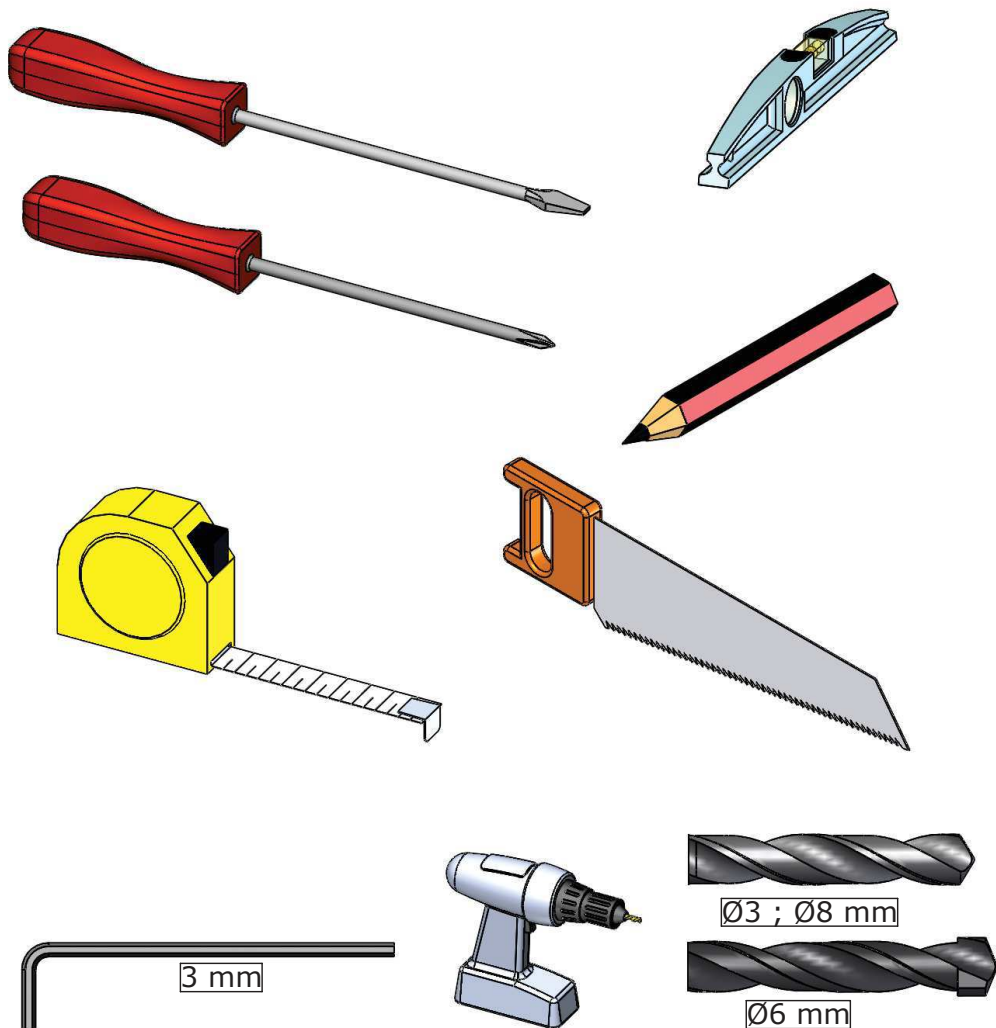

X2

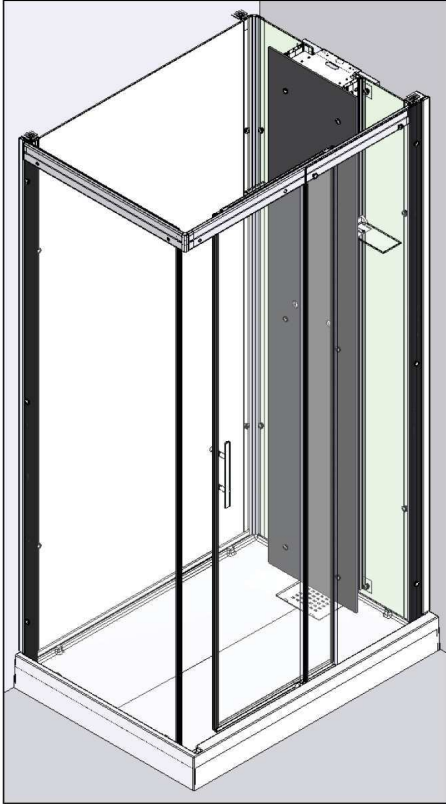
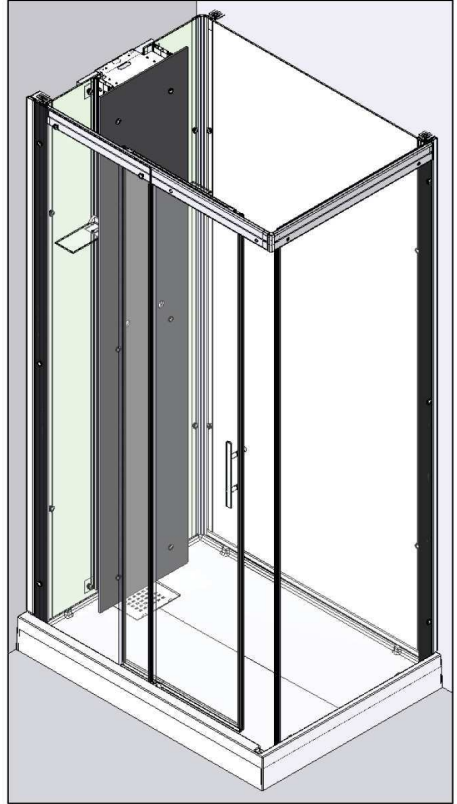

REVERSIBILITE
REVERSIBILITYMONTAGE A GAUCHE
LEFT HAND VERSIONMONTAGE A DROITE
RIGHT HAND VERSION

Vous avez la possibilité de réaliser un montage à droite ou un montage à gauche. Notre notice d'installation décrit un montage à gauche. Si vous voulez réaliser un montage à droite, il vous suffit d'inverser le montage.
Dans le cas d'un verre avec sérigraphie, selon le sens de montage, la sérigraphie peut se retrouver à l'intérieur ou à l'extérieur de la cabine.

This cubicle can be installed either left or right hand. This installation instructions shows a right left installation.
For a screenprinted glass, depending on assembly, the screen printing can end up inside or outside.

01

Ø6 mm

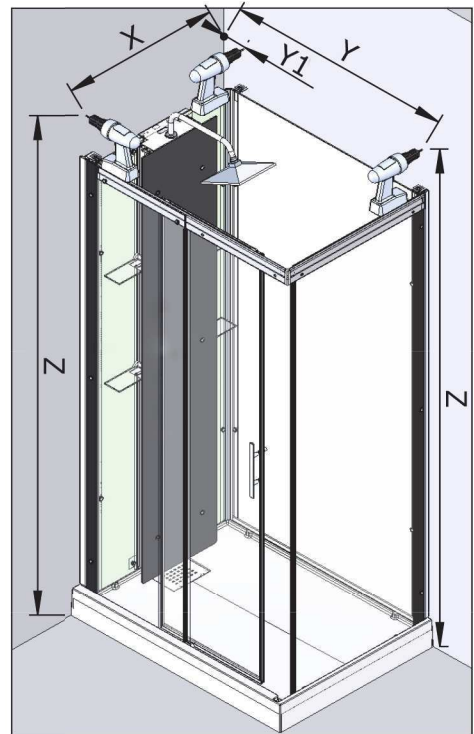
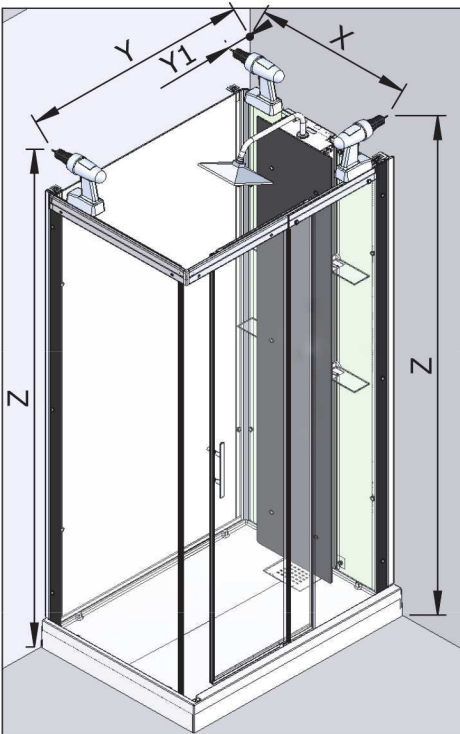

	110x80	120x90
X	74cm	84cm
Y	103cm	113cm
Y1	10cm	10cm
Z	207,5cm	207,5cm

02

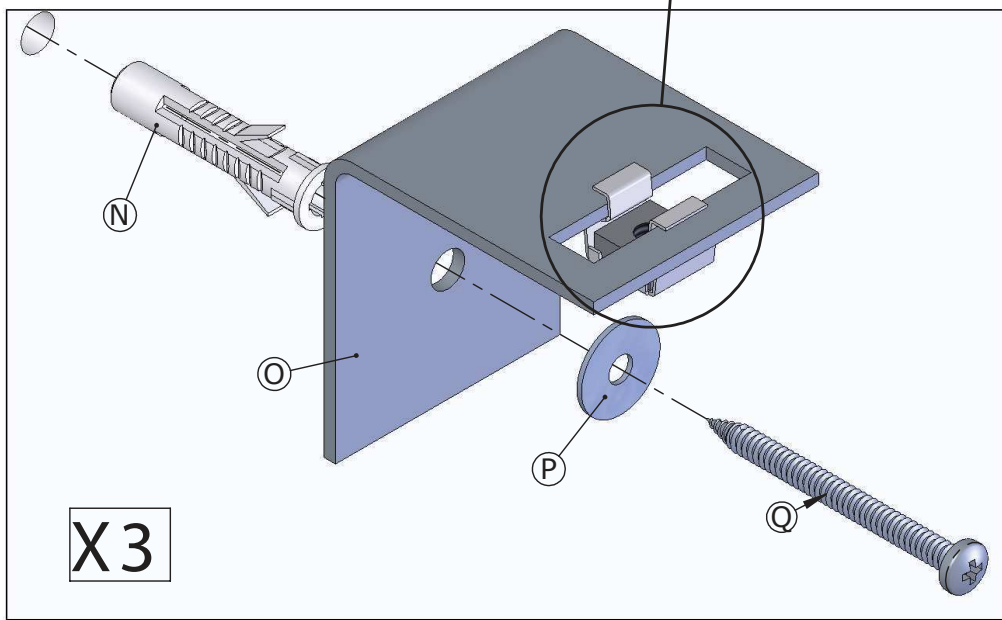
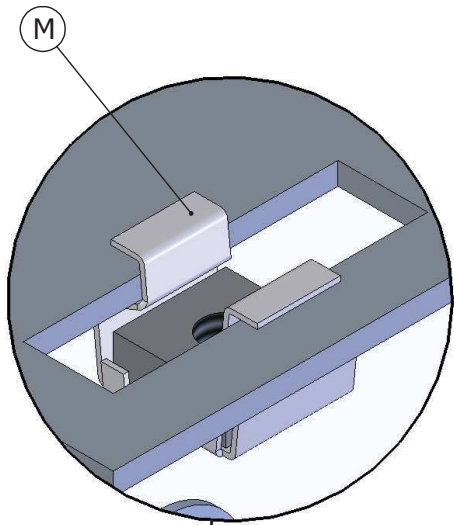

X3

03

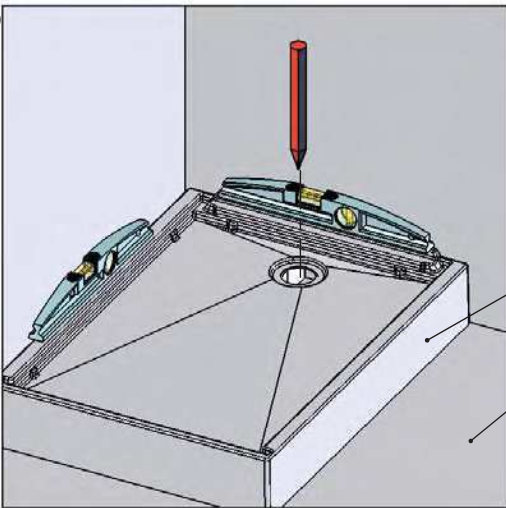

(A)

Sol rigide indispensable.
The underlying surface must be perfectly rigid.

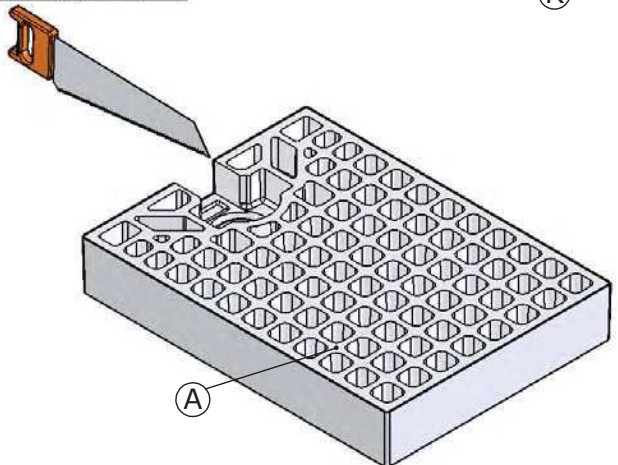
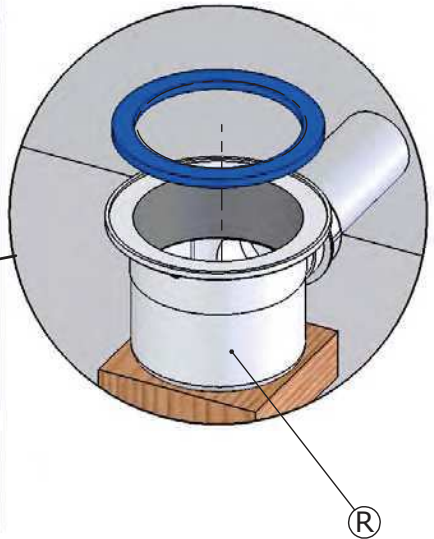
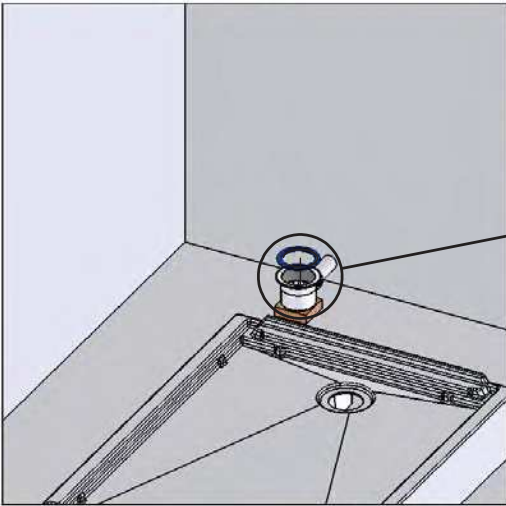

04

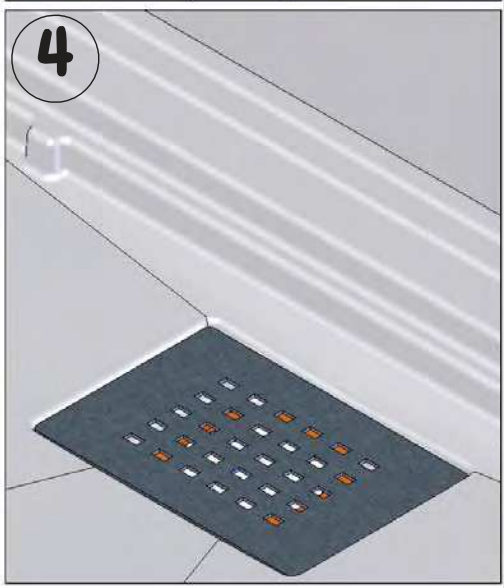
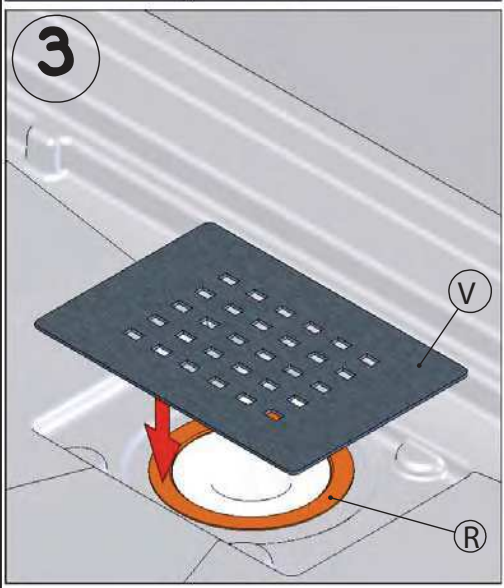
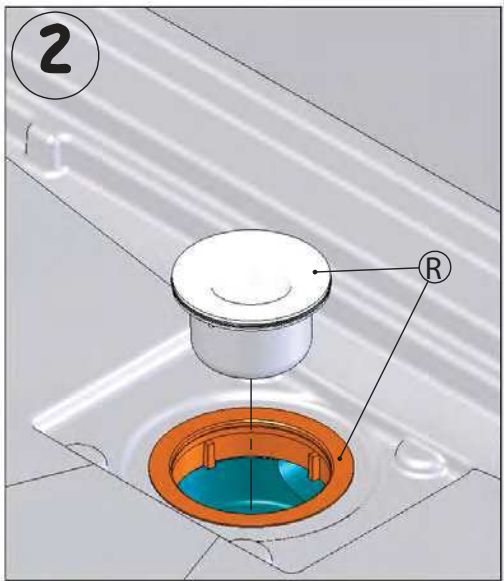
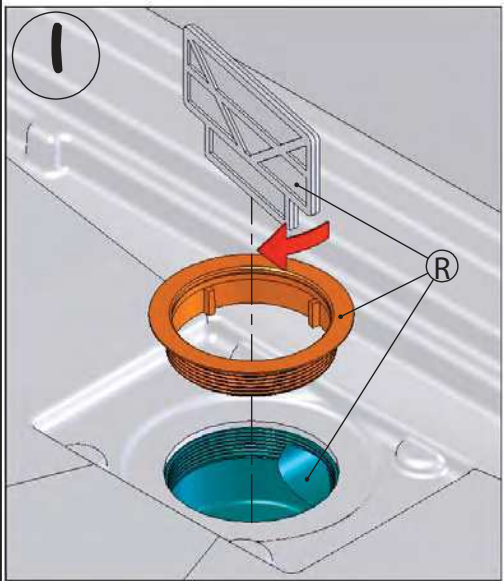

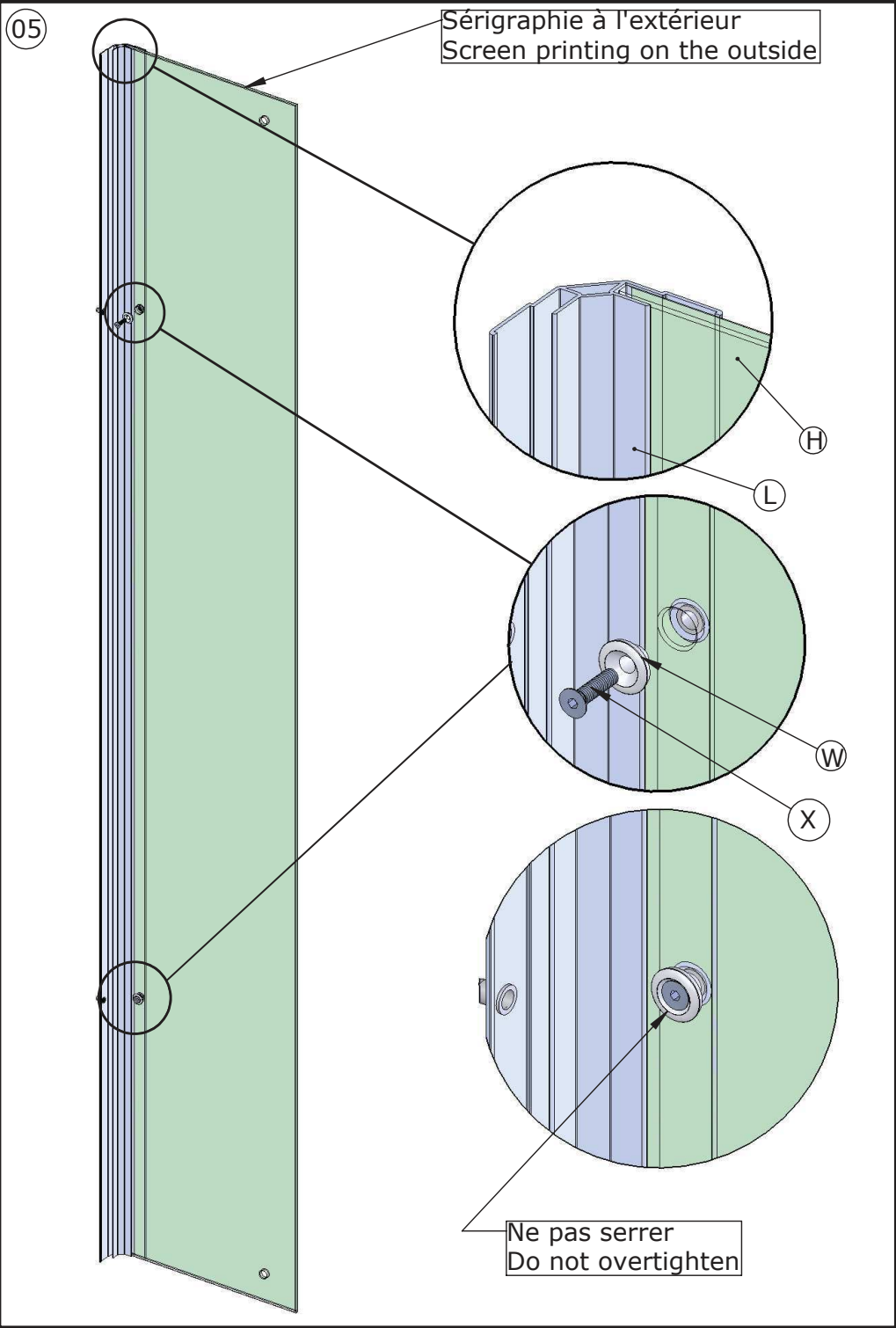

06 Sérigraphie à l'extérieur
Screen printing on the outside

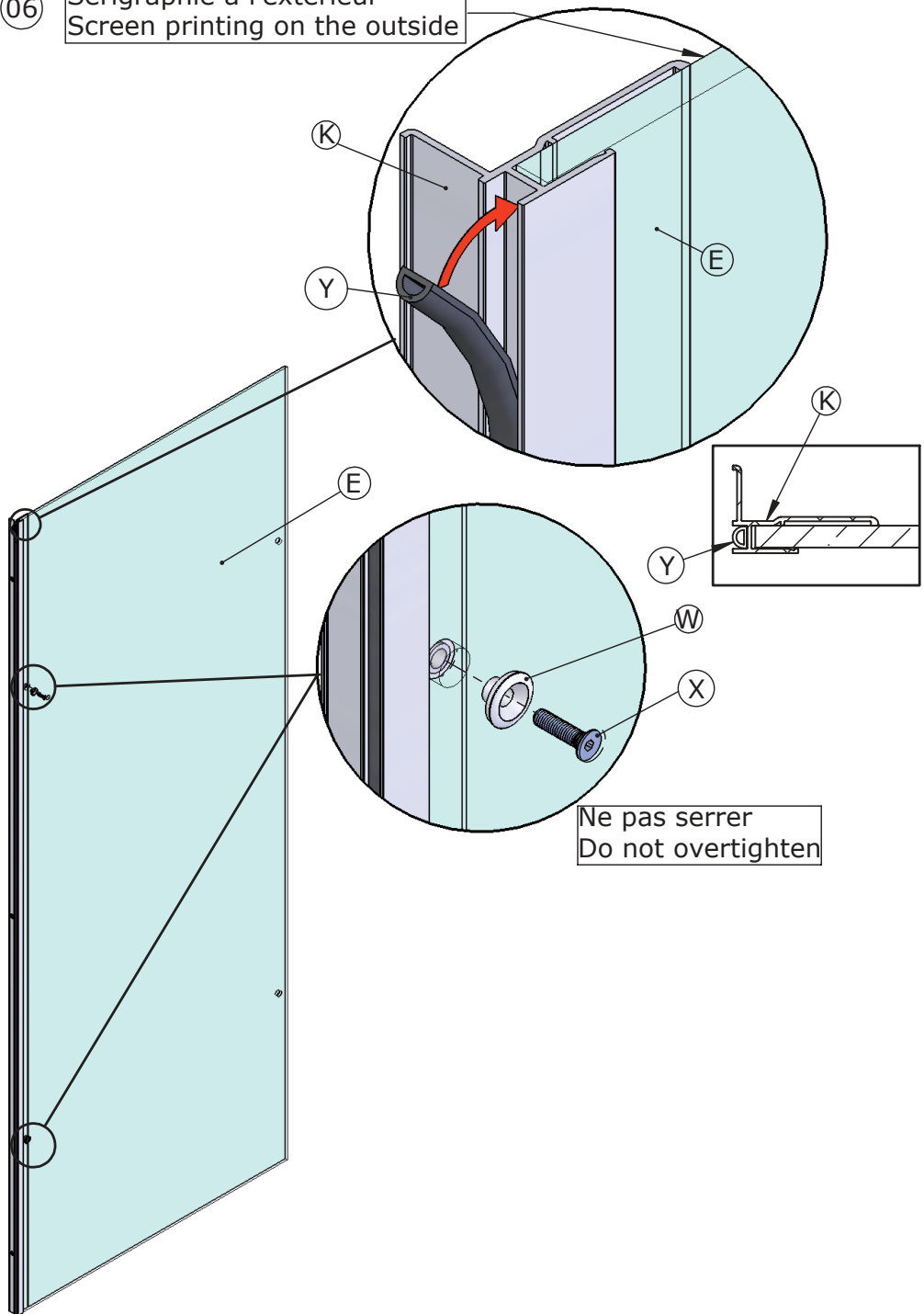

Ne pas serrer
Do not overtighten

07

Sérigraphie à l'extérieur
Screen printing on the outside

Fixer d'abord le grand panneau
First fix the big panel

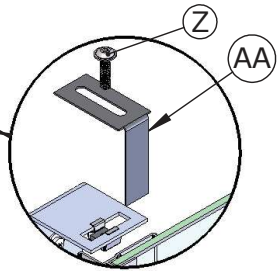
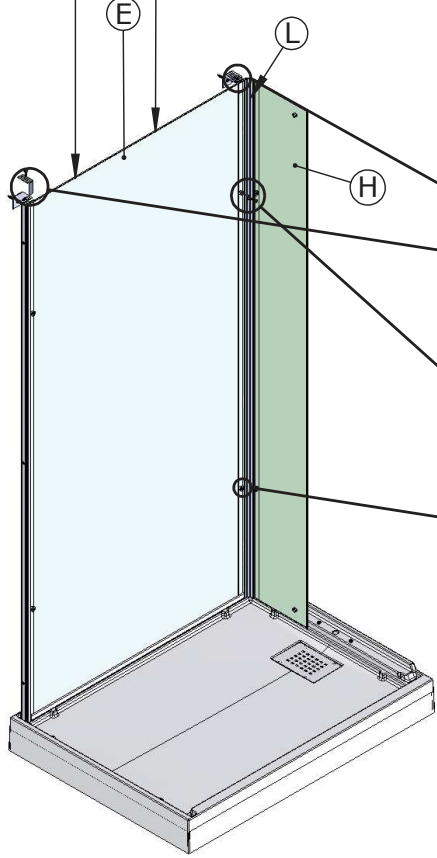

Ne pas serrer
Do not overtighten

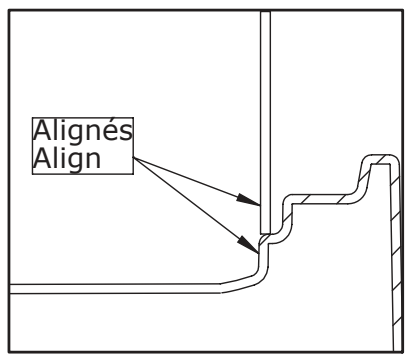
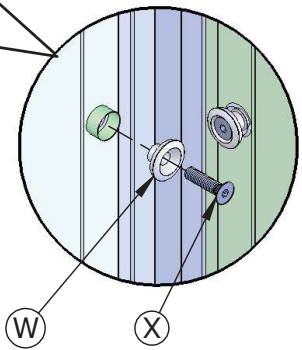

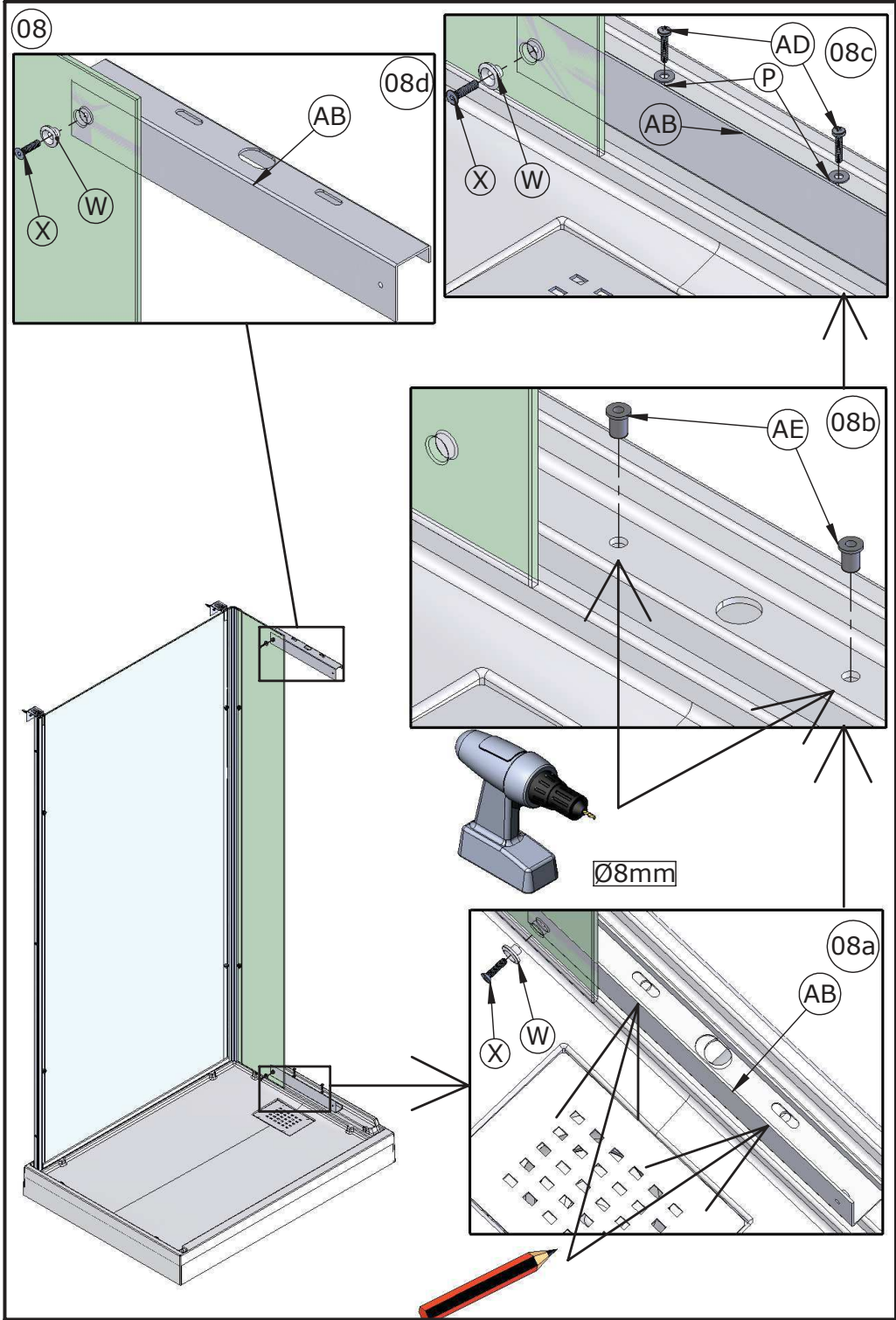

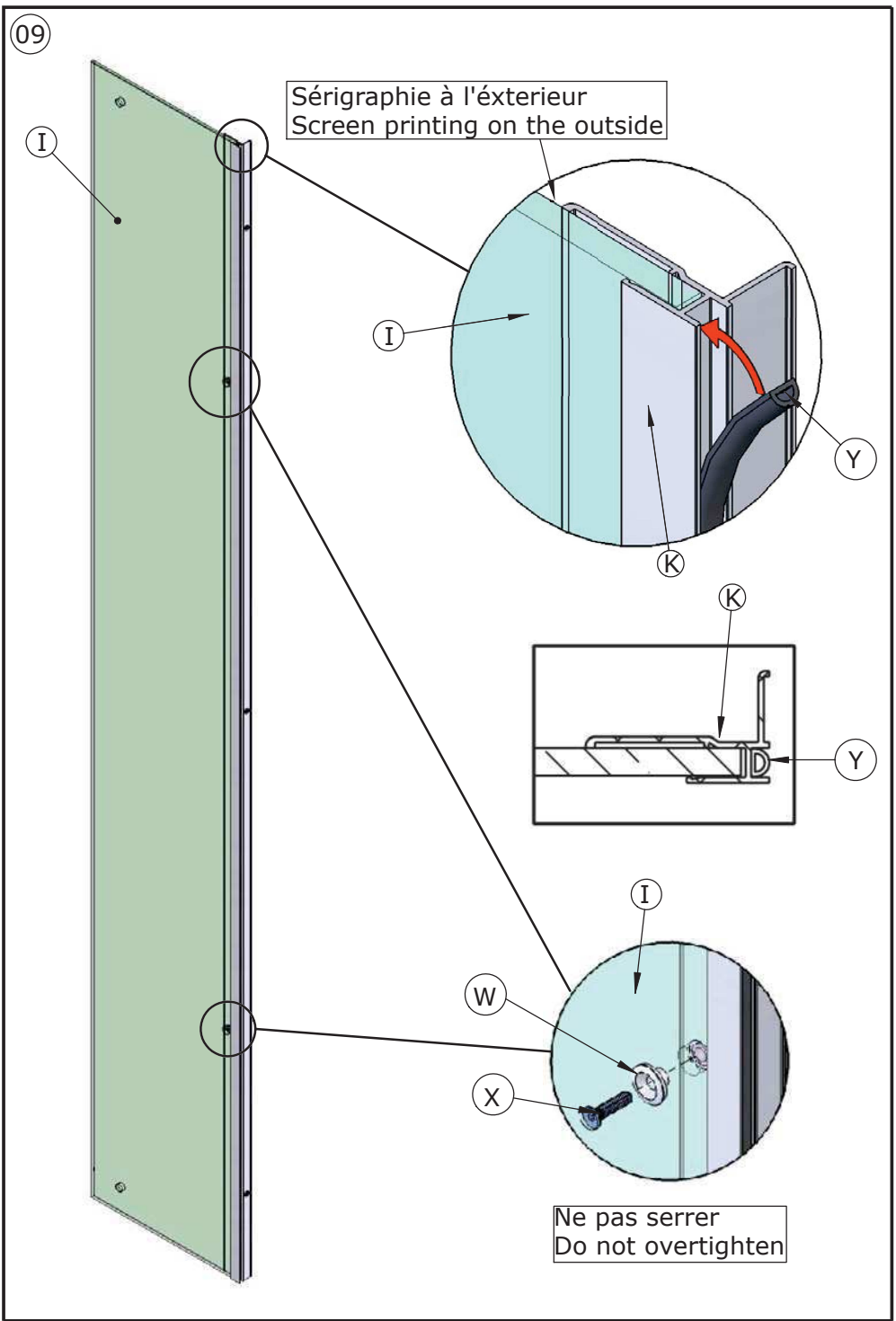

10

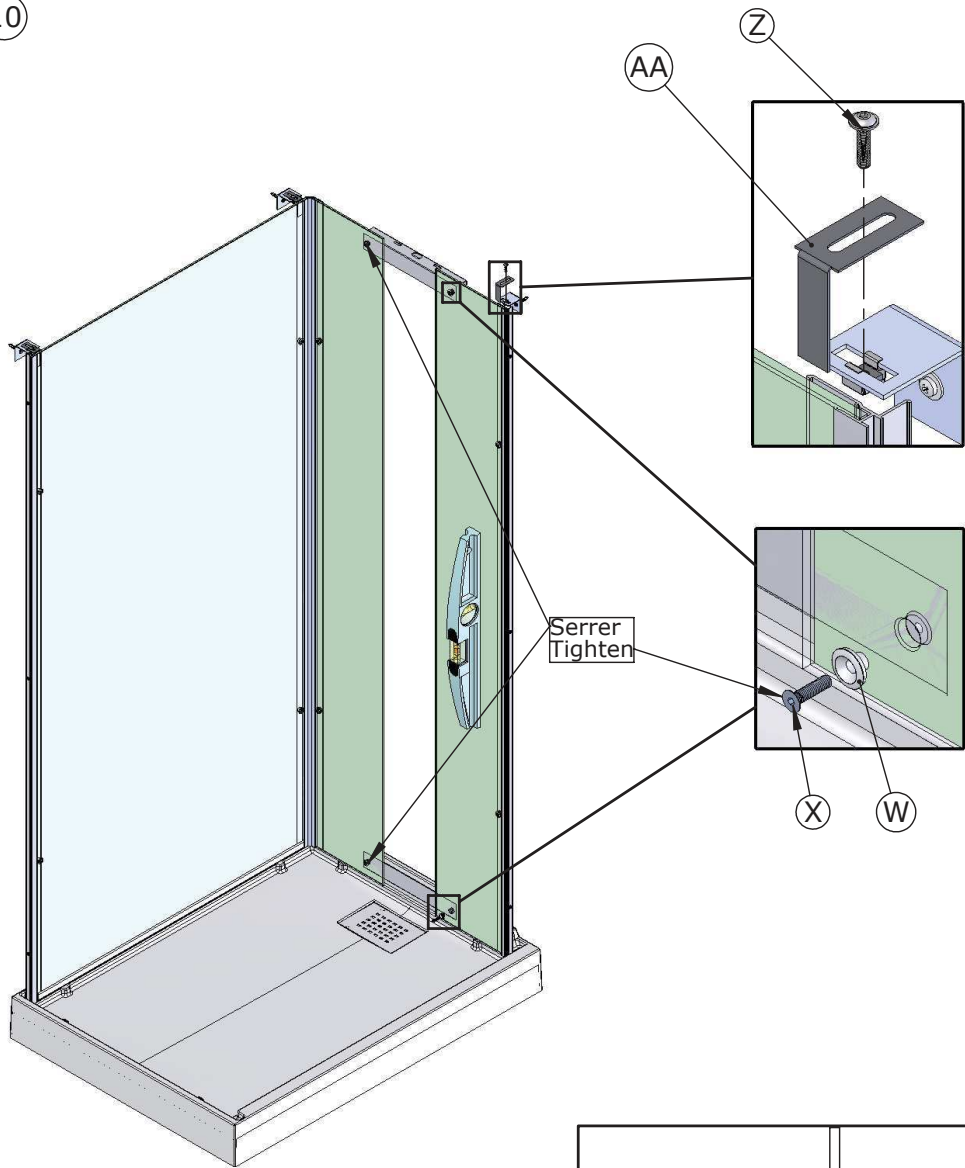

Serrer
Tighten

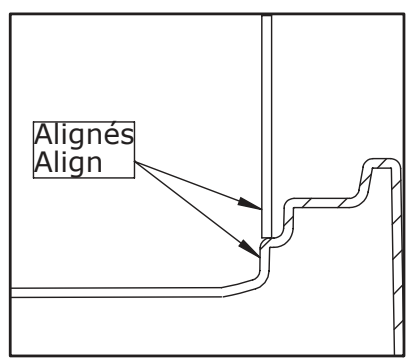
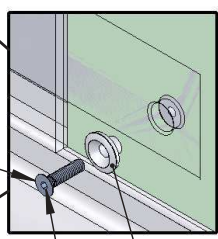
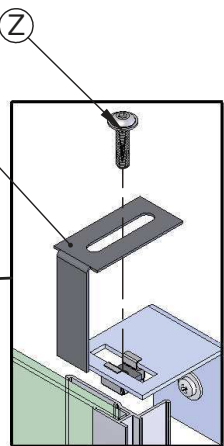

Alignés
Align

11

B

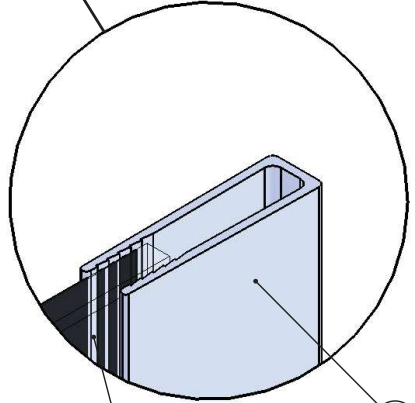
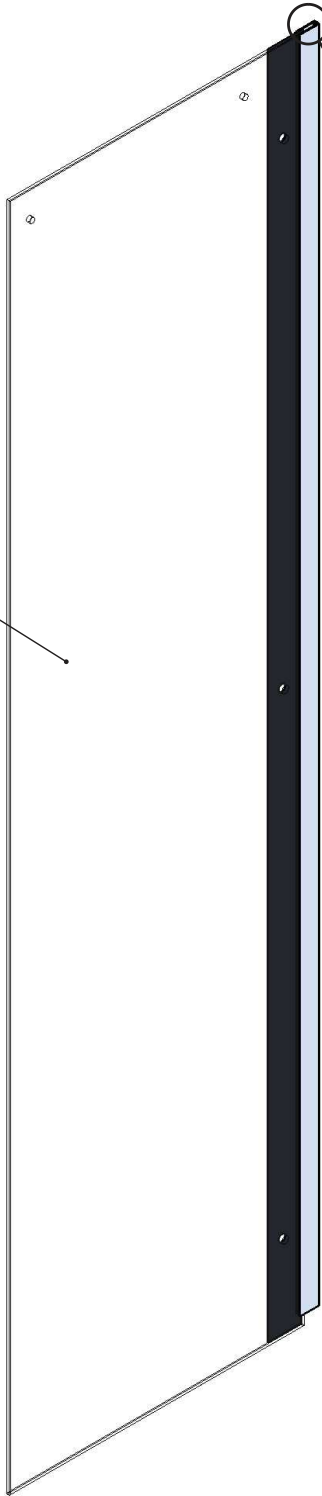

B

AF

12

Perçage en haut
Drill holes on top

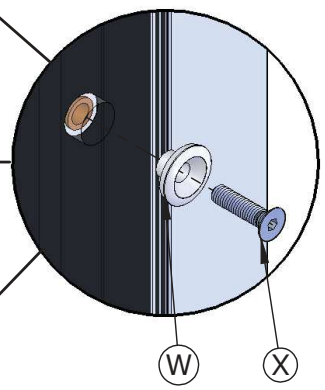
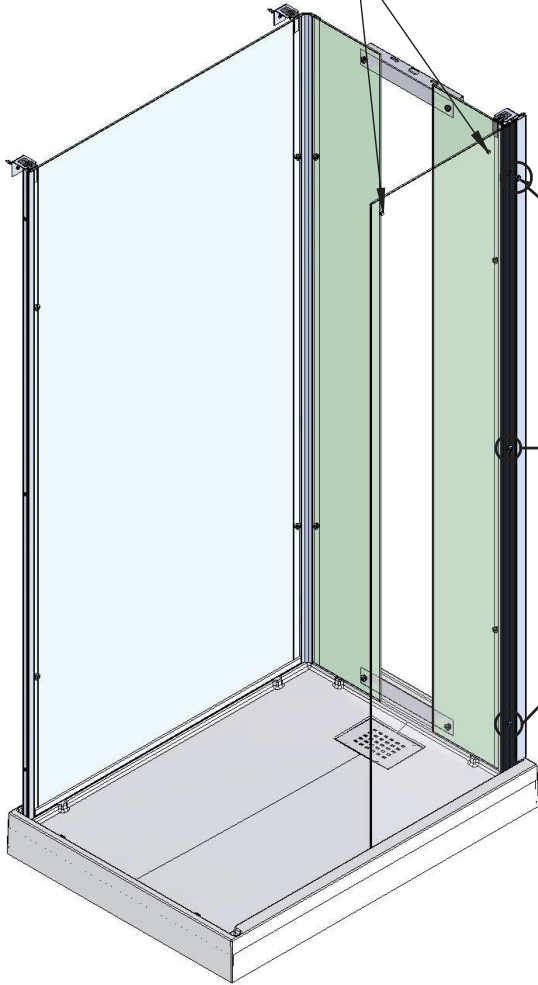

Ne pas serrer
Do not overtighten

13

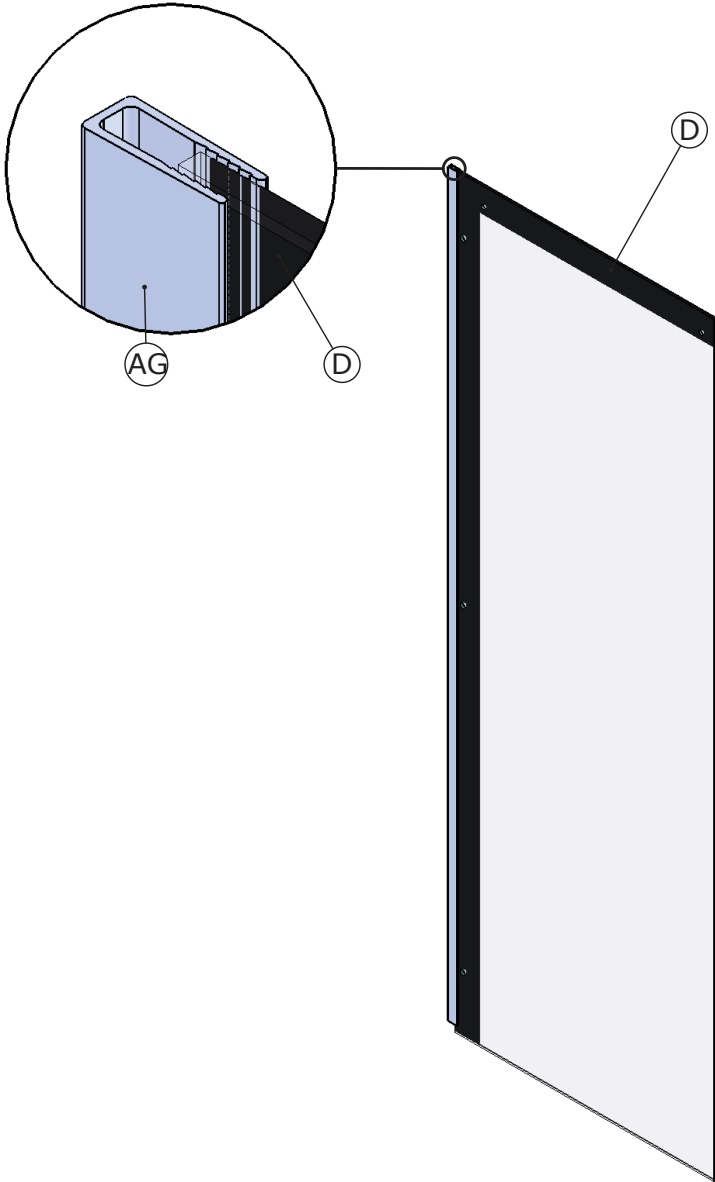

14

Perçage en haut
Drill holes on top

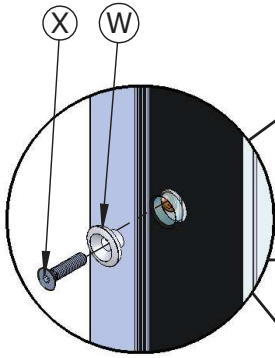

Ne pas serrer
Do not overtighten

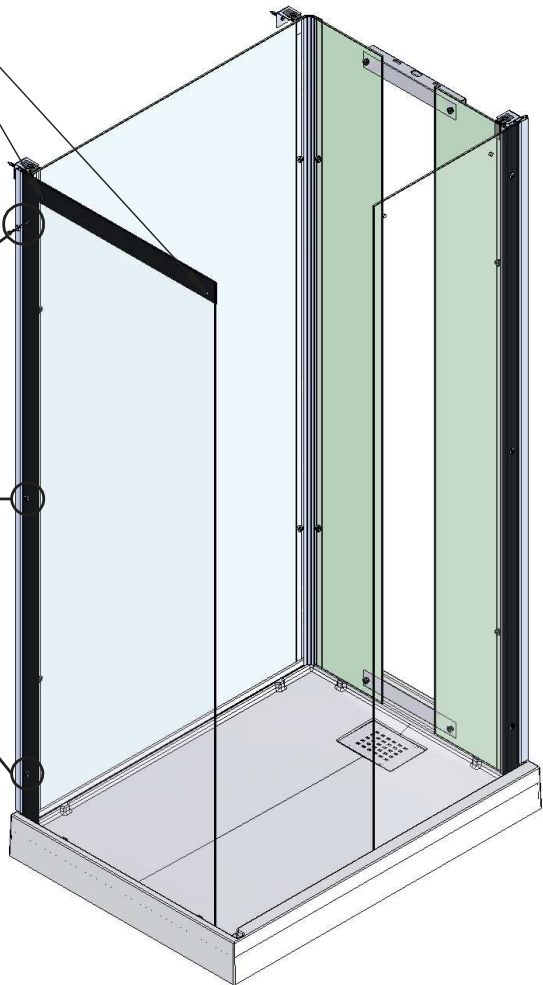

15

Gabarit de positionnement
Template for the correct installation

(AH) Ø8 mm

(B)

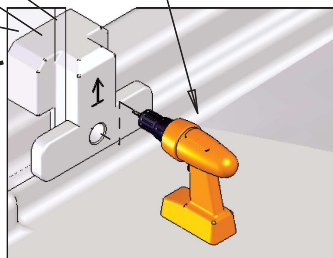

(B)

(AE)

(AI)

(AD)

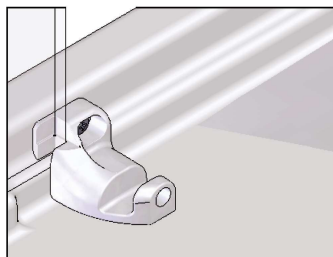
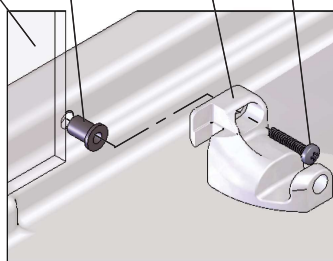

(AI)

Assurez-vous du bon positionnement
des verres avant de percer.
Ensure glass panels are fully home
before drilling.

16

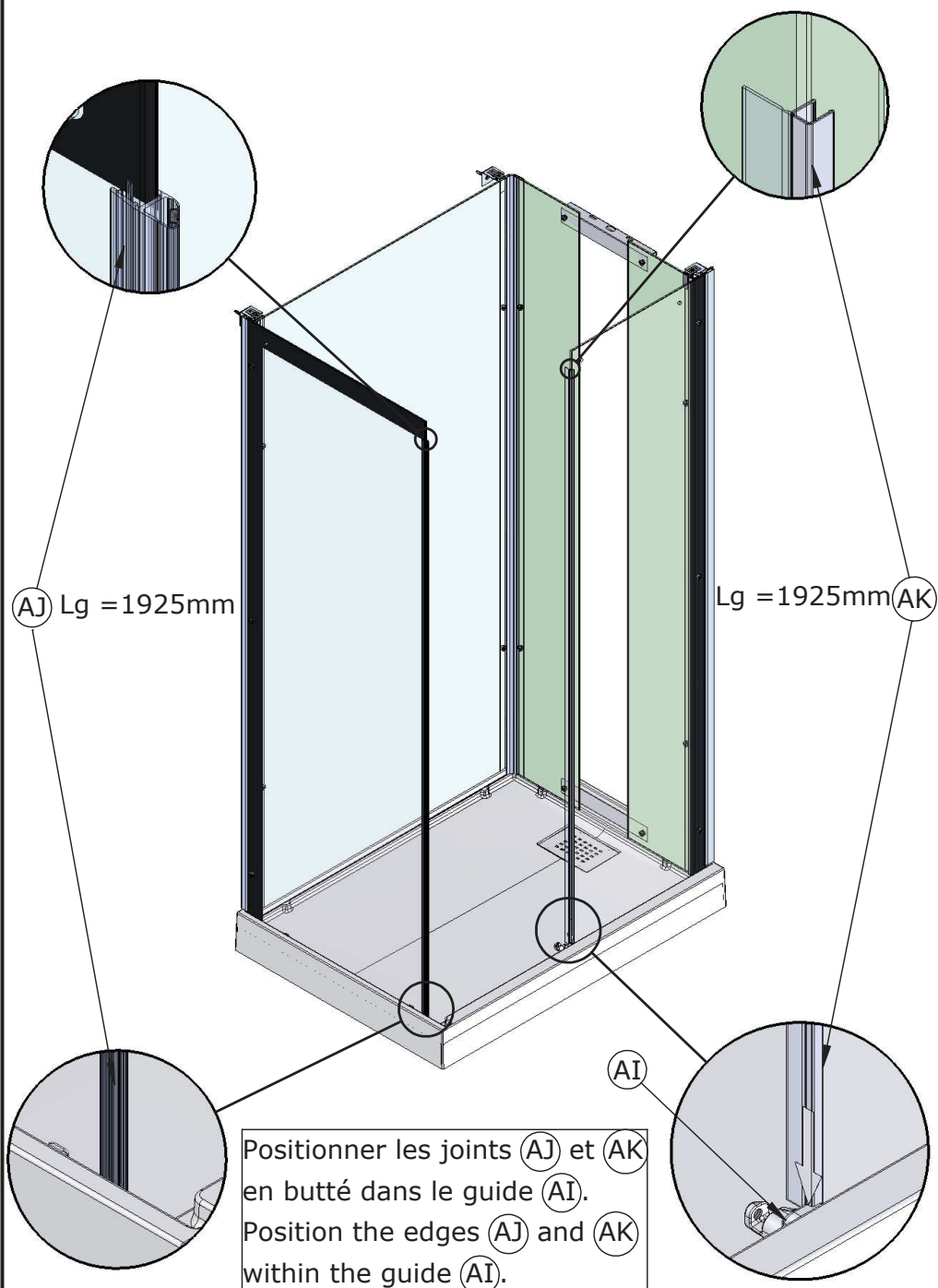

17

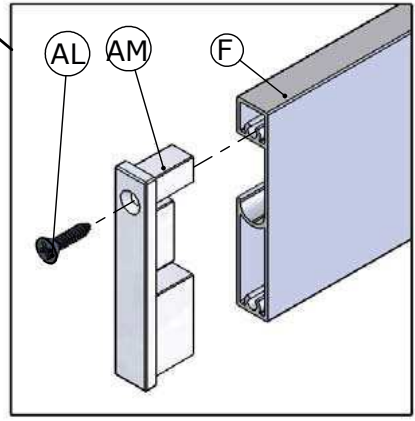
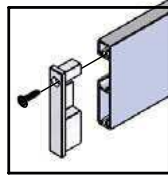
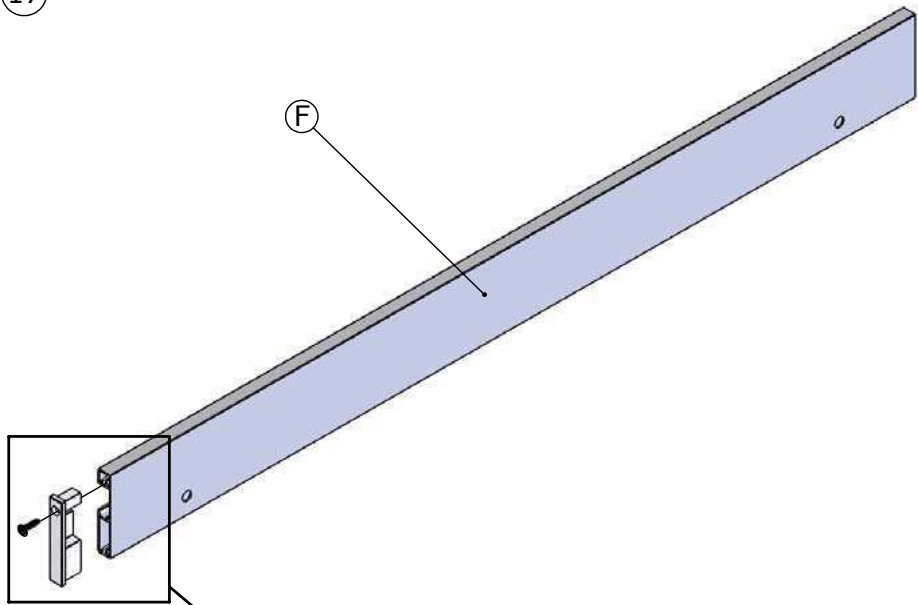

18

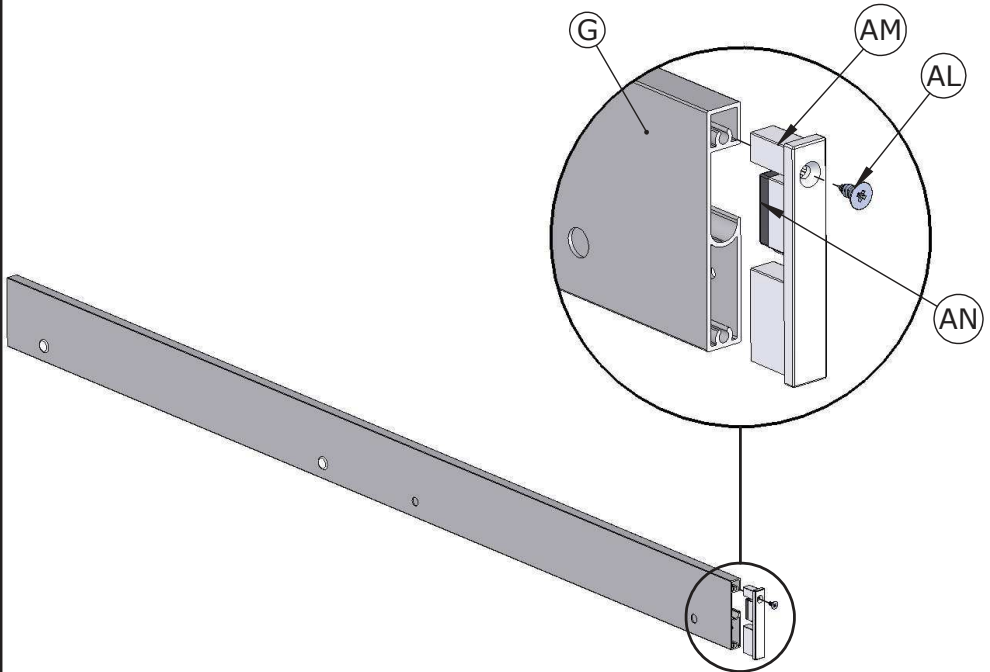
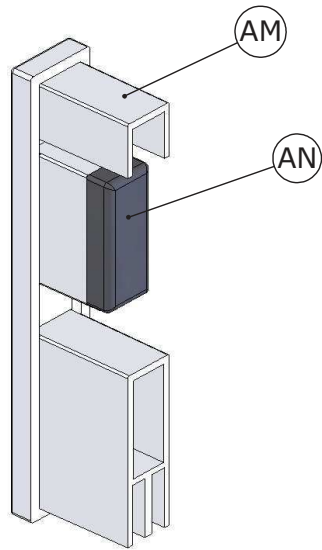
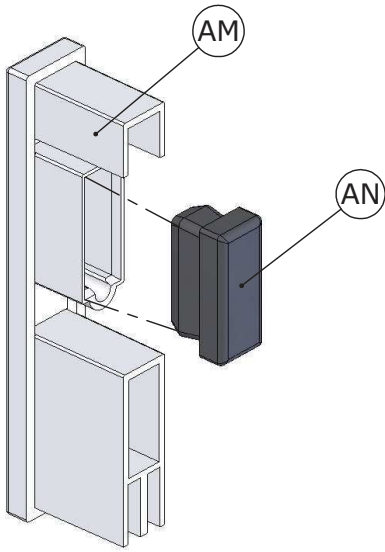

19

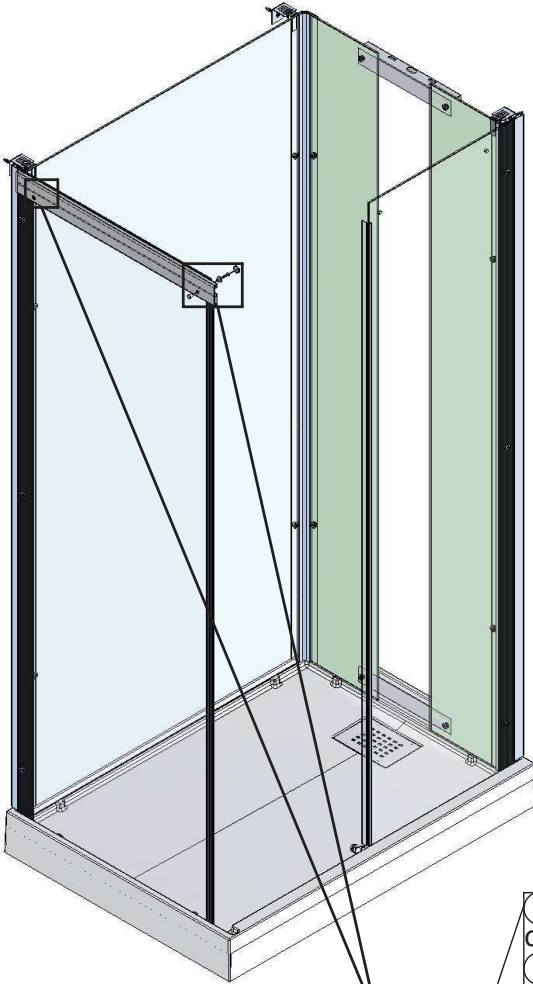

Ⓕ est à l'extérieur
de la douche.
Ⓕ is outside the shower.

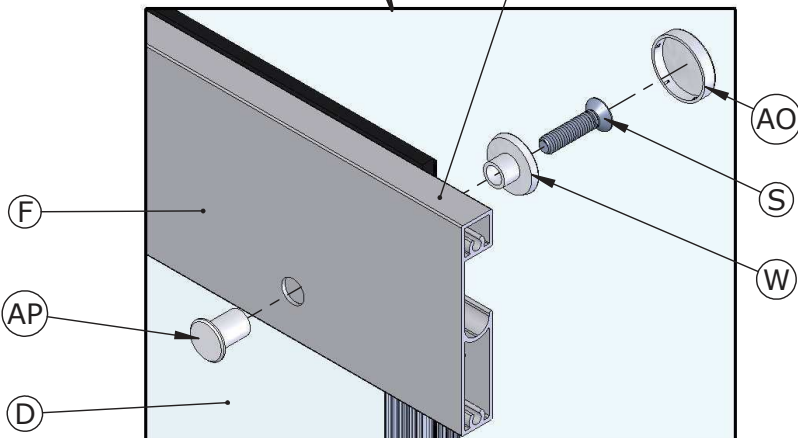

20

G est à l'intérieur de la douche.
G is inside the shower.

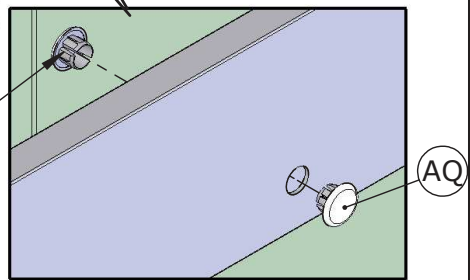
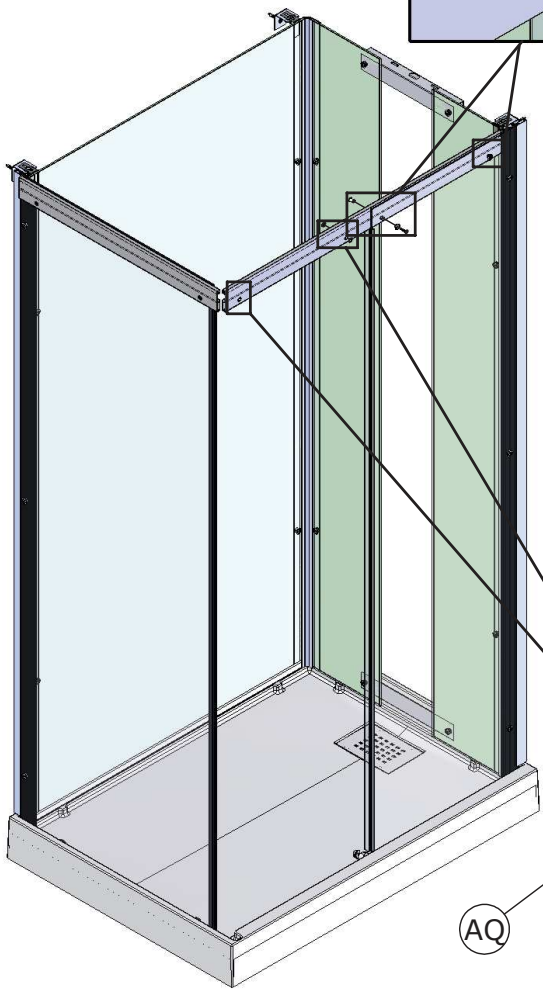
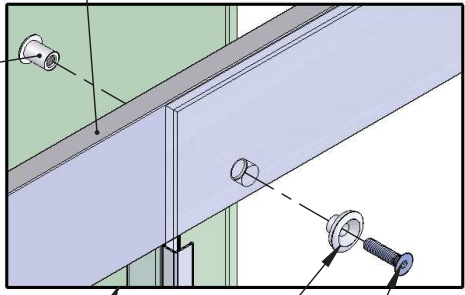

21

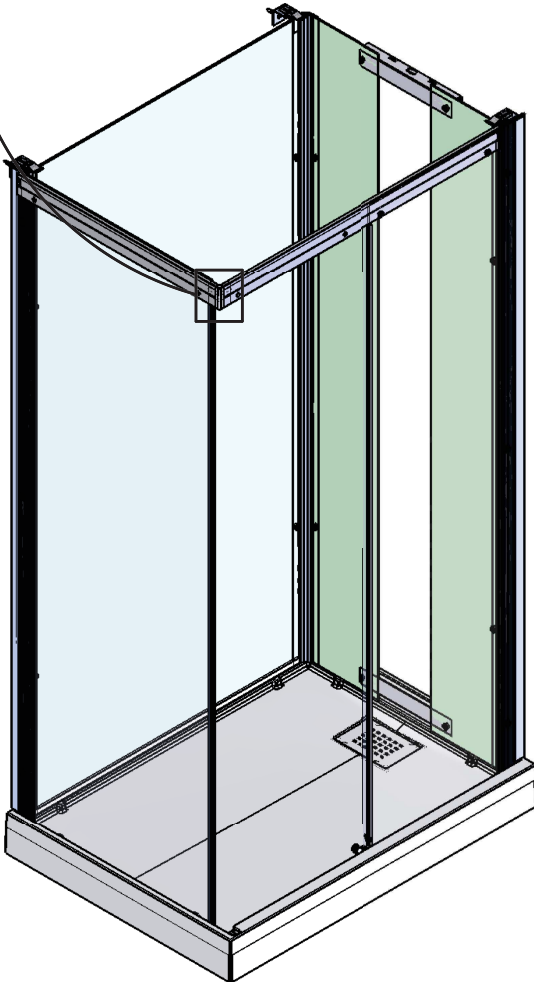
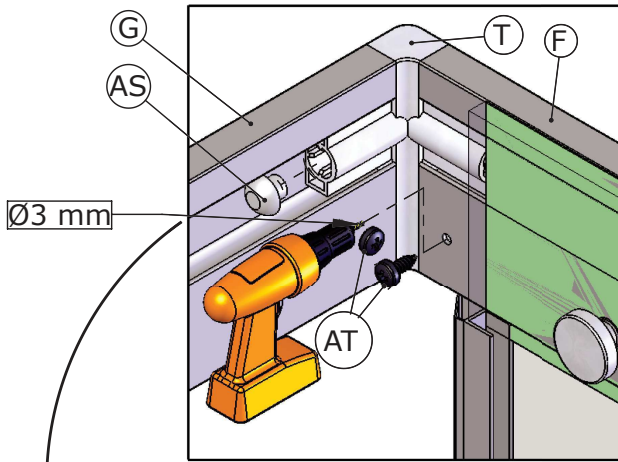

22

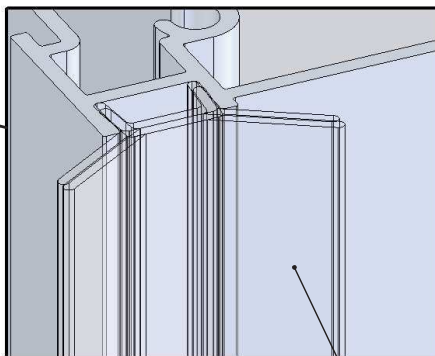
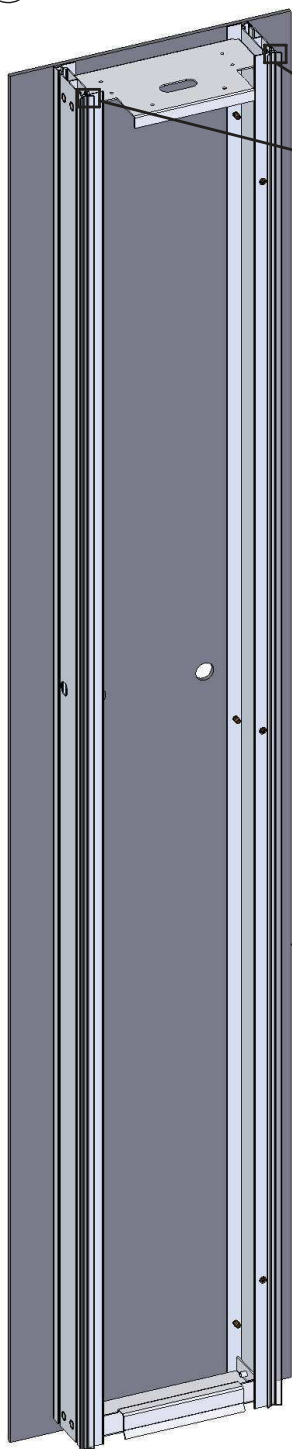

AU

**INSTALLER LA
ROBINETTERIE.
INSTALL YOUR
SHOWER.**

Monter à l'arrière
du mitigeur
si nécessaire.
Mounting behind
the shower
if necessary.



X2

U

SET01

23

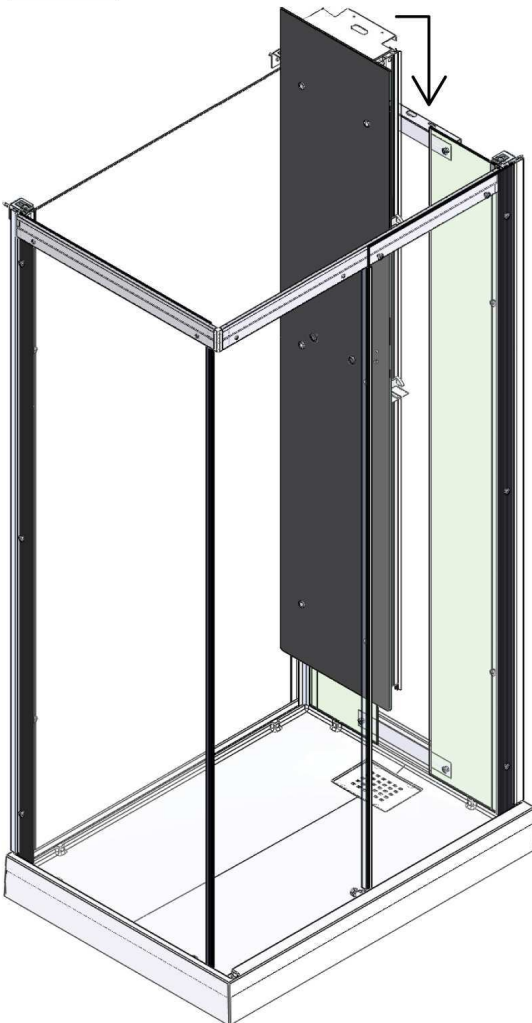
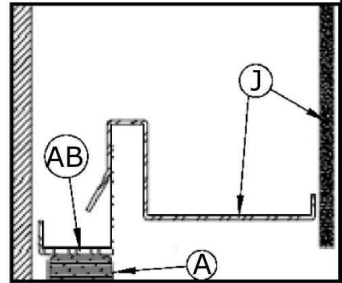
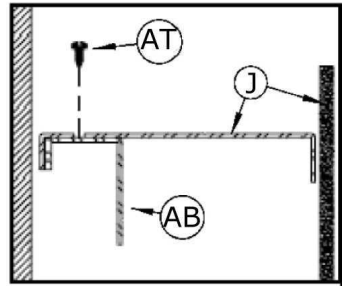
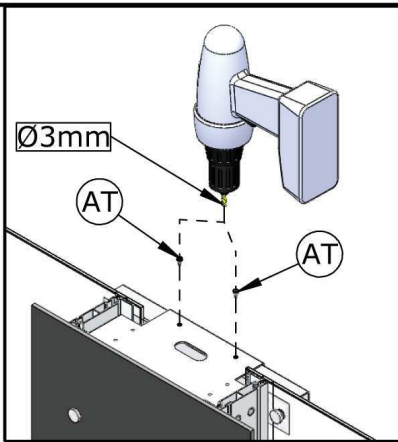

Connecter l'arrivée
d'eau et la liaison
équipotentielle

Connect the water
supplied and check
for leaks at this
point and connect
the earth connector

24

Voir la notice poignée
Check handle installation instructions

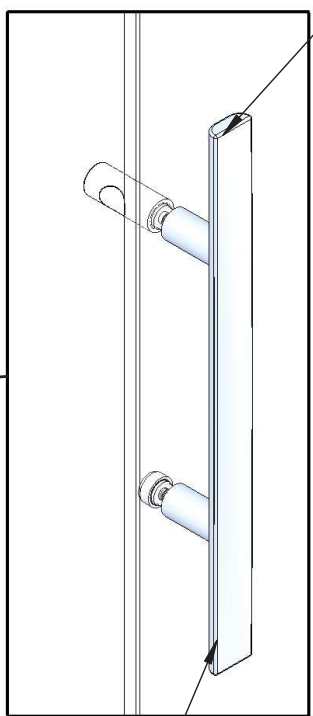
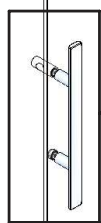

AW

25

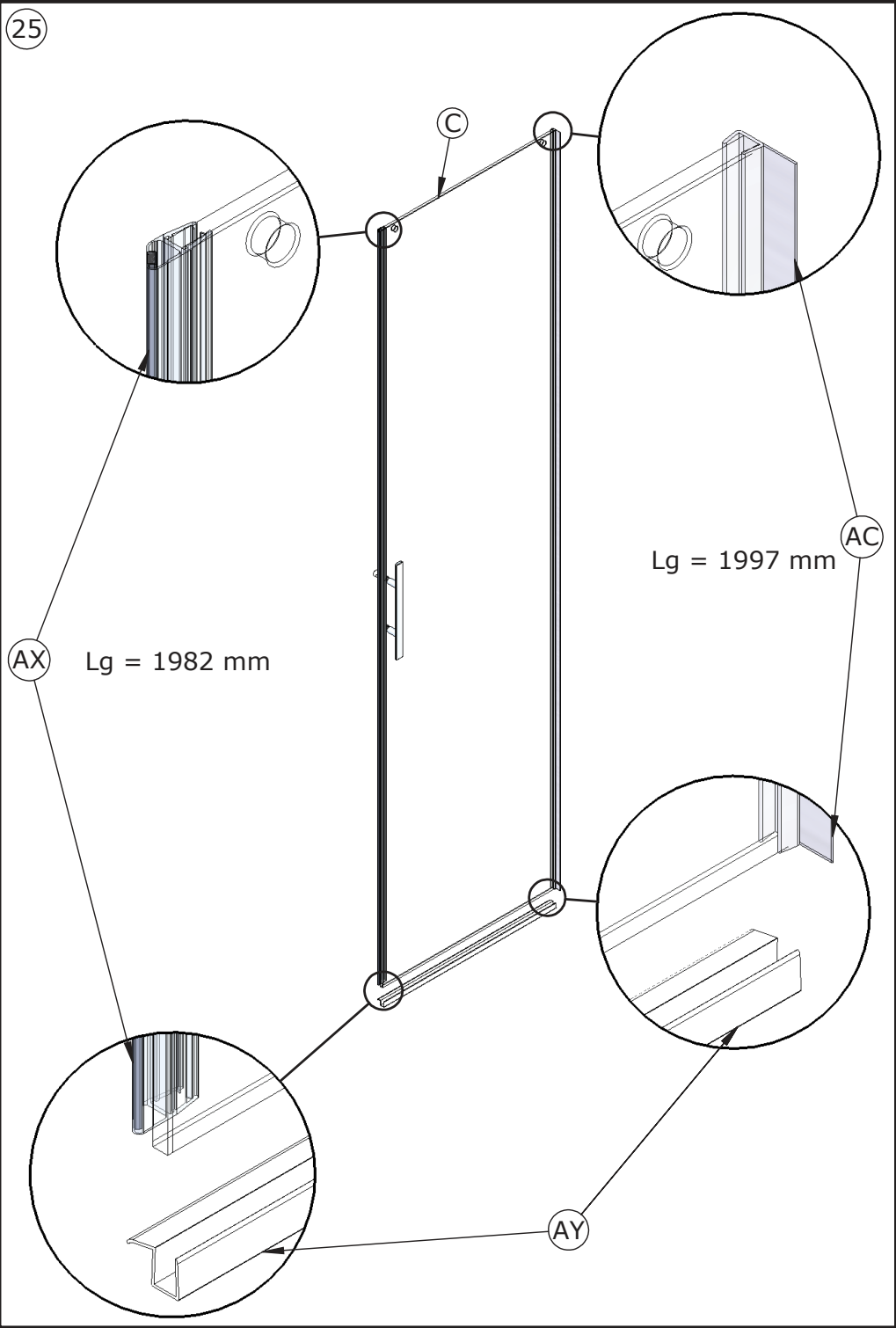

26

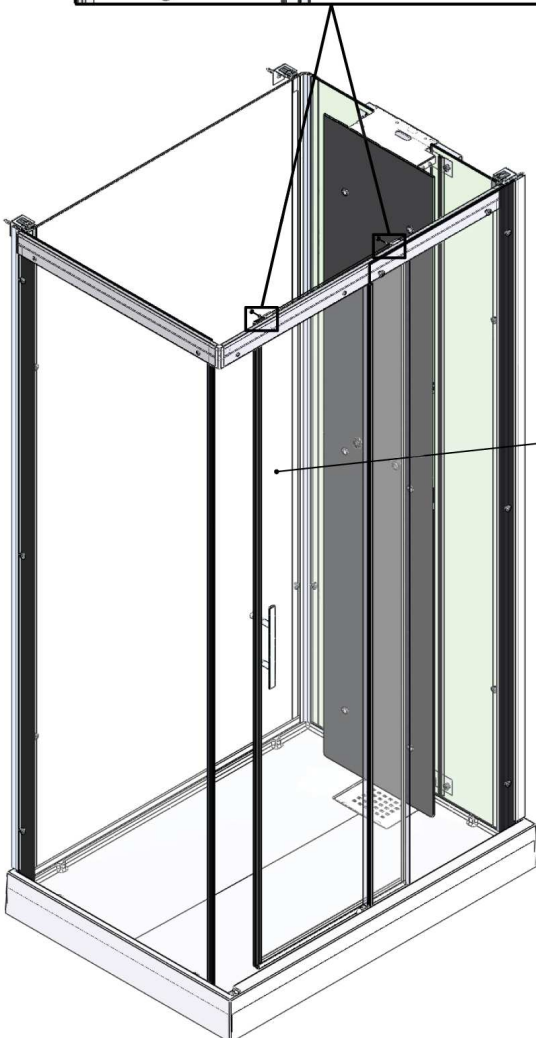
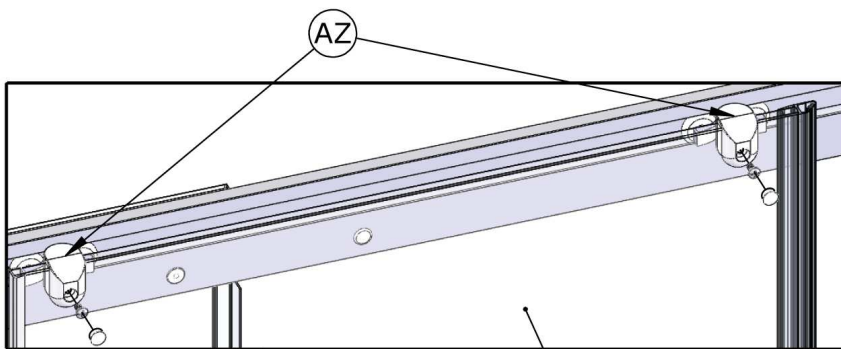

Placer les roulettes dans les rails puis fixer les portes dans les roulettes.
Place the rollers into the top rail then attach the door to the rollers. Ensure rollers are at the highest adjustment.

C

27



AR

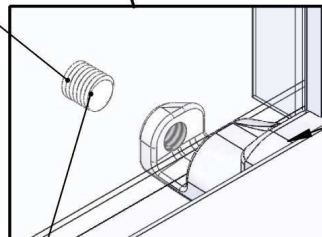

AI

Serrer, puis desserrer d'un demi tour.
Hand tighten then back off half a turn.

28

Vérifier l'aplomb de la cabine
Check that the cubicle is level

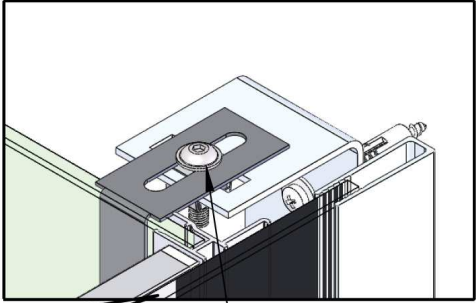
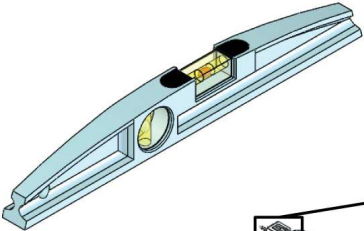

Serrer
Tighten

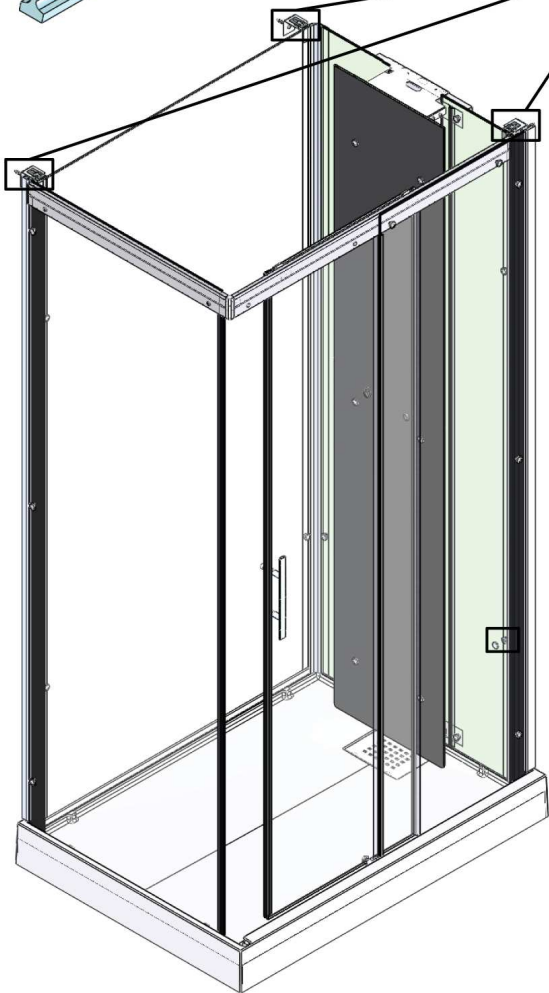

X18

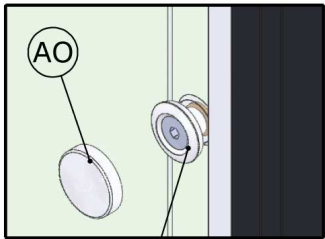

Serrer
Tighten

29

Voir la notice d'utilisation et d'entretien
See the instructions for use and maintenance

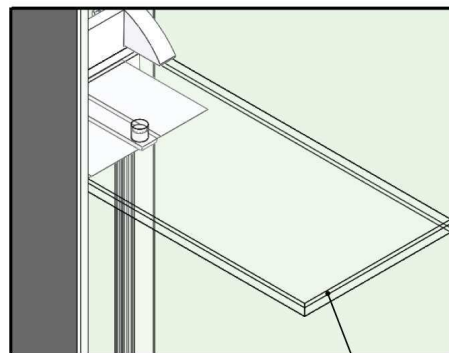

AV

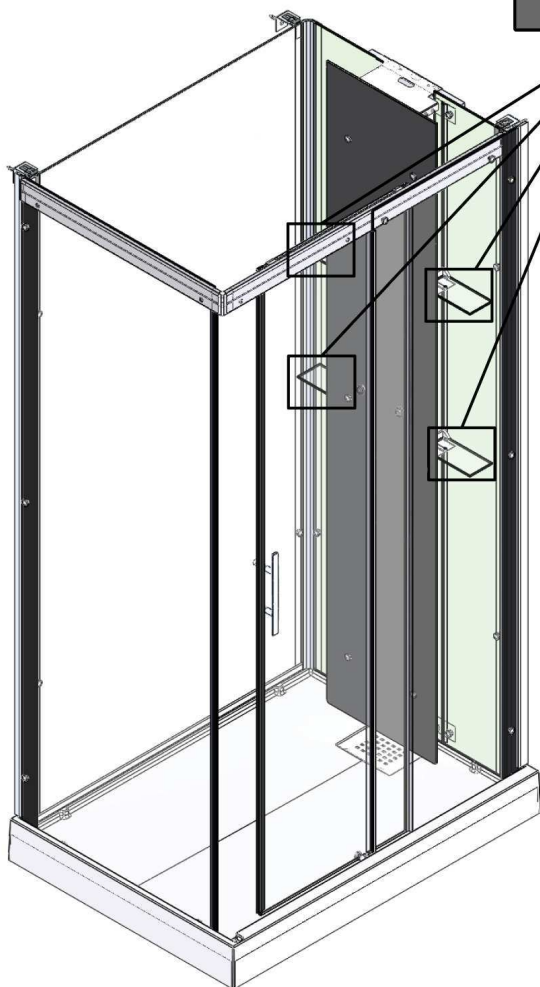

30

Réglage des portes
Adjust the doors

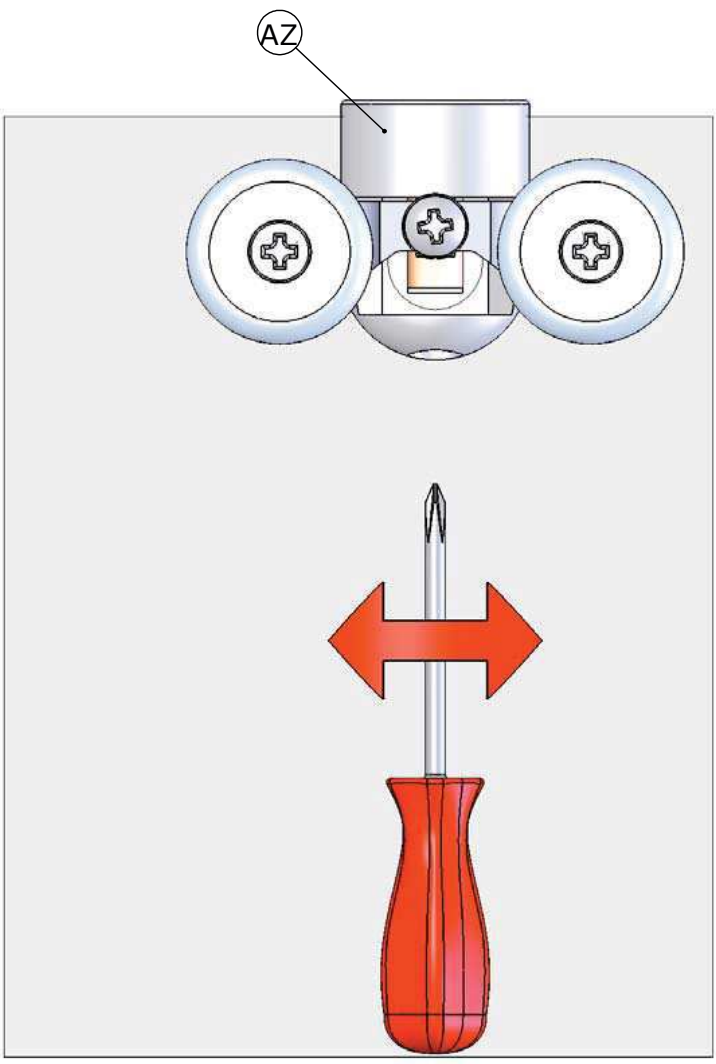

REGLAGE DES ETAGERES
ADJUSTMENT OF SHELVES
REGOLAZIONE MENSOLE
AJUSTE DE LAS ESTANTERIAS
VERSTELBARE REKKEN

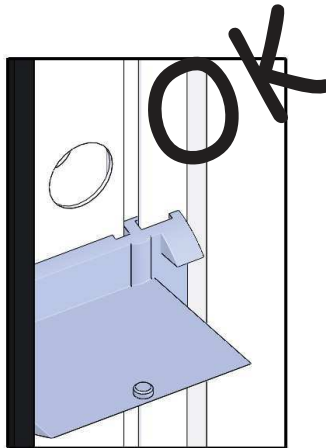
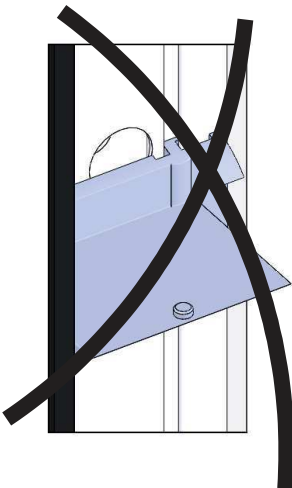
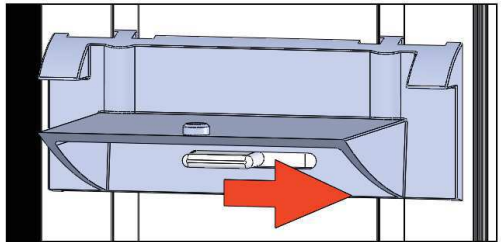
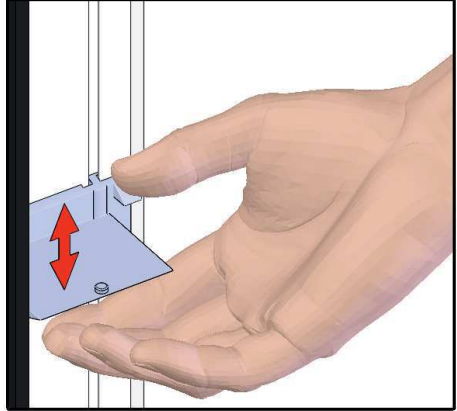
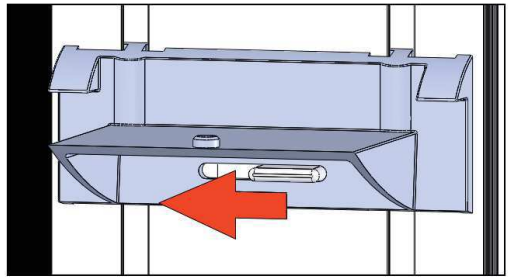



SAV
SERVICE HELPLINES
ASSISTENZA POST-VENDITA
SERVICIO POSTVENTA

FRANCE

02 40 21 29 45

SCHWEIZ

(01) 748 17 44

UK

020 8842 0033

ESPANA

93 544 60 76

IRELAND

04697 33102

NEDERLAND

0475 487 100

DEUTSCHLAND

0800 82 27 82 0

BELGIE

+31 475 487 100

ITALIA

(0382) 6181

BELGIQUE

+31 475 487 100

OSTEREICH

(0222) 21 402 16 0

РОССИЯ

963 19 40, 773 67 22